

Takara Belmont Shampoo Units

YUME ESPOIR II YUME SUITE II YUME NOBLE II

Model numbers [Basin] AY-EXES2R*
[Chair] AY-SCES2B*/AY-SCES2P*/AY-SCSB2*
[Seat] AY-UES2B*/AY-UES2P*/AY-USI2*/AY-UNB2*

Operating Instructions

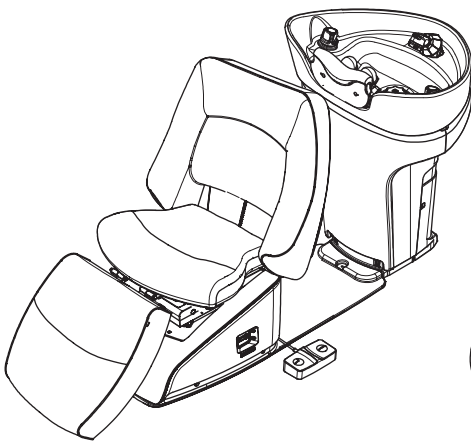

(This illustration shows
AY-EXES2R/AY-SCES2B/AY-UES2B.)

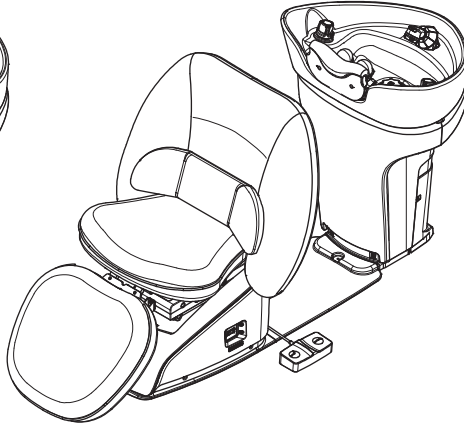

(This illustration shows
AY-EXES2R/AY-SCSB2/AY-USI2.)

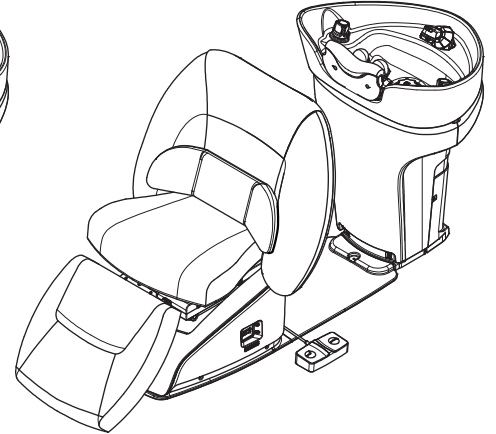

(This illustration shows
AY-EXES2R/AY-SCSB2/AY-UNB2.)

Thank you for purchasing this Takara Belmont product.

Please read the Operating Instructions carefully before use and use the product appropriately.

Failure to read them before use may lead to an accident.

- Keep these Operating Instructions near the product so that you can read them at any time. Read them again as and when necessary.
- This product is an industrial appliance for use in hairdressing salons. Use this product only for its intended purpose.
- The product must only be used by properly trained professionals such as hair stylists and aestheticians.
- Only qualified technicians (from Takara Belmont or your local authorised Takara Belmont dealer) are permitted to install and assemble the product.

If the Operating Instructions become illegible due to stains or rips, or if this booklet is misplaced, please request a copy from Takara Belmont using the enquiry number shown in the box below.

Version 3 2025.03

Table of Contents

Introduction

Description of Warning Symbols	4
Safety Precautions	5
Precautions for Use	12
Precautions for Synthetic Leather Care	14
Precautions for Use of Basin Products	14
Precautions for Use of Resin-plated Parts	15
Warning Label Locations	15
Before Using the Product... ..	16
Accessories	16
Part Names	17

Preparation

Attaching/Removing the Neck Cushion	20
Attaching the Head Cushions	21
Using the Lumbar Cushion (SUITE 2, NOBLE 2)	22
Turning on the Power	22

How to Use

Lifting/Lowering the Seat	23
Changing the Preset Position	24
Using the Shower Head	25
Using the Tablet Case (Optional)	26
Adjusting the Flow Rate	27
Adjusting the Water Temperature	28
Filling the Basin with Hot Water	30
Shampooing	31
Space between the Chair and the Basin	36
Using the Heater(s) (ESPOIR 2 Premium, SUITE 2, NOBLE 2 with Heater(s))	37

Cleaning

Cleaning Instructions	38
-----------------------------	----

Table of Contents

Instructions to Read When Necessary

Troubleshooting	47
Daily Inspection	49
Regularly Replaced Parts	52
Standard Period of Use	52
Consumables	52
Disposal of the Product	53
After-sales Service	53
Specifications	53
Product Dimensional Drawings	55

Description of Warning Symbols

■ Before using the product



Please be sure to read the Safety Precautions and Precautions for Use carefully and use the product correctly.

■ About the items listed here







These are intended for the safe use of the product and to prevent harm and damage to users and other people.

All of the precautions shown are important details related to safety. Please be sure to follow them. If an accident occurs due to failure to follow the Safety Precautions, the Precautions for Use, the Precautions for Synthetic Leather Care, the Precautions for Use of Basin Products, and/or the Precautions for Use of Resin-plated Parts, Takara Belmont will not be responsible for any damage or risk to the person using this product or those around them due to the accident. In this case, the person failing to adhere to the Safety Precautions, the Precautions for Use, and/or the Precautions for Synthetic Leather Care will be responsible for any damage or risk incurred.

Detailed descriptions of graphical symbols are provided below. Read and understand the meanings of these symbols thoroughly before reading these instructions.

Symbols	Magnitude of harm/damage and urgency
 WARNING	The items explained under this symbol are precautions that, if not followed, may result in death or serious injury from incorrect handling of the product.
 CAUTION	The items explained under this symbol are precautions that, if not followed, may result in mild or moderate injury or property damage from incorrect handling of the product.

Individual items that must be complied with are explained under the following symbols:

Graphical symbols for prohibited actions	Graphical symbols for mandatory actions
 Symbol for general prohibitions	 Symbol for general mandatory actions by the user
 Symbol for prohibition of disassembly, repair, and modification	 Symbol indicating the equipment's power plug must be disconnected from the outlet
 Symbol for high temperature caution notices	 Symbol for earth connection

Safety Precautions (to be strictly observed)

WARNING

Power plugs and cords



● **Do not plug or unplug the equipment with wet hands.**

Touching the power plug or outlet with wet hands may cause an electric shock.

● **Use the power cord at the rated voltage.**

Do not use the power cord outside the rated voltage. Fire, electric shock, or malfunction may result.



● **Use a separate outlet for the power plug.**

Use a separate AC 230V outlet (15 A or higher) with an earth terminal. Sharing the outlet with other equipment may generate abnormal heat and cause fire.

● **Insert the power plug securely.**

Insert the power plug fully into the outlet.

If inserted part way, the power cord may cause a short circuit or generate heat, and fire may result.

● **Hold the power plug when disconnecting it.**

To unplug, hold and pull the power plug, not the power cord. Unplugging by pulling the power cord could damage the power cord and may cause an electric shock or fire.

● **Inspect the power plug and cord for damage.**

If the power cord or plug is damaged or the power plug is loose in the outlet, do not use this product. Otherwise, an electric shock or fire may result.

● **Remove any accumulated dust from the power plug and the outlet with a dry cloth.**

Failure to do so may result in a fire.



● **Be sure to connect the earthing conductor.**

Failure to do so may cause an electric shock in the event of a mechanical failure or electric leakage.

Consult a professional to perform proper connection to the electrical earth.

Installation and moving



● **Precautions for installing this product**

- This product must be installed in accordance with the Installation Instructions.
- Only qualified technicians (from Takara Belmont or your local authorised Takara Belmont dealer) are permitted to install and assemble the product.
- Make sure to install this product only on a flat, solid surface, and fix it firmly.
- Install the product in a place with adequate space and where there are no obstacles around the product.

When using or cleaning the product ...



● **Keep hands, fingers, and other body parts as well as the clothes of both the client and the user well away from the moving parts of the equipment and its surroundings.**

Otherwise, the client or the user may become caught and injured.

● **Do not let the client lie face down.**

Unexpected operation of the chair may cause personal injury.

Safety Precautions (to be strictly observed)

WARNING

When using or cleaning the product ...



- **Do not stand on the chair.**

You may fall down, resulting in personal injury or damage to this product.

- **Do not sit on the backrest, leg rest, or basin.**

Do not sit or place excessive weight on the backrest, leg rest, or basin. You may fall down, resulting in personal injury or damage to this product.

- **Do not use this product in an environment where electromagnetic interference is present.**

Do not install this product near communication equipment, elevators, or other devices that generate electromagnetic waves.

In addition, do not use devices that generate electromagnetic waves, such as mobile phones, near this product. Malfunction may result.

- **Do not allow two or more people or a person weighing more than 135 kg to get on the chair.**

They may fall down, resulting in personal injury or damage to this product.

Allowing a person weighing more than 135 kg to get on the chair may also cause the chair to malfunction or become damaged. Damage to the chair may result in injury.

- **Do not sit on the leg rest.**

The chair may become damaged.

- **Do not operate the foot switch while sitting on a stool.**

While sitting on a stool for shampooing, do not manipulate the foot switch to operate the chair. Before operating the chair, stand up and make sure there are no obstacles within the chair's operating range.

- **When working between the chair and the basin, do not lean on the basin.**

During treatment, do not lean on the basin. The basin may tip over or your clothes may become stained by the colouring agents on the neck cushion or basin.

- **Do not allow water to spill out of the basin.**

- Be careful not to get water on any part of the product other than the basin. If water does get on any part of the product other than the basin, wipe it off immediately. If water gets inside the equipment, mechanical failure may result or electricity may leak and cause fire.

- Be careful not to spill water on the floor. If water does get on the floor, wipe it off immediately. Otherwise, damage to the floor or a water leak may result.



- **Precautions for automatic operation**

During automatic operation, keep close watch on the client. The automatic operation may cause the client unexpected stress due to posture changes, which may result in injury. [See page 24.]

- **Be careful not to touch the switch during treatment.**

During treatment, take extra care not to activate the foot switch by accidentally touching it, or trip over the foot switch or base plate. Sudden operation may result in injury.

Safety Precautions (to be strictly observed)

WARNING

When using or cleaning the product ...



- **While working between the backrest and the basin, be careful not to accidentally step on the foot switch.**

If you accidentally step on the foot switch, the backrest may fall, and you may become trapped between the backrest and the basin. In the event of becoming trapped between the backrest and the basin, follow the procedure instructed in 'If you are trapped by the backrest' [page 36] to escape.

- **Keep an eye on the client and any nearby children.**

- Keep an eye on the client while using this product. Intentional or accidental contact with a switch by the client may cause this product to operate unintentionally, resulting in an accident. **Be careful particularly when small children are around the product.**
- Keep children away from this product, except for the child receiving treatment.

- **If the chair does not operate or shows any abnormality, stop using it.**

If the chair does not operate or shows any abnormality, stop using it and immediately contact your local authorised Takara Belmont dealer.

- **Pay attention to the space between the chair and the floor.**

When the seat is lowered, the tip of the leg rest will be very close to the floor. When lowering the seat, always make sure there are no people, pets, or objects underneath. Be extra careful particularly when small children are around the product. Failure to do so may cause a person, pet, or object to become caught between the leg rest and the floor, resulting in personal injury or damage to this product.

- **Precautions for operating the chair or setting the preset position**

- Before and during operation of the chair, check carefully for any objects, hands, or feet that might be within or near its operating range. Otherwise, the object or body part might become caught in the chair, and personal injury or damage to this product may result.
- When operating the chair, make sure the client is sitting deep in the seat with their feet on the leg rest. During operation, keep close watch on the client.
- Do not touch the switches with wet hands. An electric shock may result.

- **Make sure the client's feet do not hit the wall in front.**

Before lifting or lowering the seat, make sure there will be sufficient space between the client's feet and the wall in front. If the client's feet hit the wall, injury may result.

[ESPOIR 2] [SUITE 2] [NOBLE 2]

When the seat is lifted from the lowest to the highest position, the tip of the leg rest will slide forward.

[ESPOIR 2]: 35 mm

[SUITE 2] [NOBLE 2]: 55 mm

See the side views [pages 55, 56, 57].

- **When the backrest is reclined, be careful not to let the client get up.**

When the backrest is reclined, applying pressure from above on the parts of the backrest where the arms are rested will cause the backrest to rise, due to its design. The client may lose their balance and become injured. [See page 32.]

Safety Precautions (to be strictly observed)

WARNING

When using or cleaning the product ...



● **Precautions when a client gets on or off this product**

- When having a client get on or off this product, make sure the seat is in the lowest position. If the client gets on or off the chair of this product from or to a wheelchair, also make sure the wheelchair is outside the chair's operating range. Otherwise, unexpected operation of the chair due to a foot or caster coming into contact with the foot switch may result in personal injury or damage to this product.
- When having a client get on or off this product, guide them to prevent them from falling.

● **After using very hot water, turn the thermostatic control knob back to a position for an appropriate temperature.**

- After using very hot water, turn the thermostatic control knob back to a position for an appropriate temperature. Failure to do so may result in burns.
- If other equipment that shares the same hot and cold water source with this product is used along with the product, the temperature may become unstable. When using other equipment along this product, turn the thermostatic control knob slowly to control the temperature.

● **Adjust the hot water temperature by checking it with your hand.**

Before adjusting the hot water temperature, reduce the flow rate and point the shower head away from the client. Then, check the temperature with your hand. Very hot water may flow out, so be careful about the operation.

● **When the product will not be in use for a long time or before cleaning it, make sure to switch it off.**

Make sure to turn off the power switch at the end of each work day, when the product will not be in use for a long time, and before cleaning the product. Otherwise, the insulation may deteriorate, causing fire due to electrical leakage, electric shock, or burns.

● **If the product will not be used for an extended period of time, switch it off at the switchboard.**

Make sure to switch off the product at the switchboard when the product will not be used for an extended period of time, such as before holidays. Otherwise, insulation may deteriorate, causing fire due to electrical leakage, electric shock, or burns.

● **Make sure to perform daily inspections.**

Using this product without daily inspections may result in personal injury or damage to this product.

For daily inspections, see [pages 49–51].

● **When the product will not be in use for a long time, turn off the heater switch(es). (AY-SCES2P*, AY-SCSB2*)**

Make sure to turn off the heater switch(es) when the product will not be in use for a long time, such as at the end of each work day.

● **If you notice any damage to the leather or any abnormality in the heater(s), discontinue use of this product.**

In the event of damage to the leather, an unusual odour (such as a smell of burning), or anything abnormal, discontinue use of this product and immediately contact your local authorised Takara Belmont dealer.

Safety Precautions (to be strictly observed)

WARNING

When using or cleaning the product ...



● **Before cleaning, turn off the power switch.**

Otherwise, an electric shock or fire may result. Also note that unexpected operation of this product may result in personal injury.



● **Action in the event of a power cut**

- Turn off the power switch to prevent unexpected operation after recovery from a power cut. Also, turn off the power switch of the device plugged into the built-in outlet and disconnect the power plug from the outlet.

- If the seat is in a high position when a power cut occurs, you cannot operate the chair to lower the seat. If you want the client to get on or off the seat in this position, exercise extreme caution, such as giving a hand to help, to prevent the client from getting injured or the chair from tipping over.



● **Avoid disassembling, repairing, or modifying the product.**

- The product must not be disassembled or repaired by people other than qualified repair technicians under any circumstances because this may result in an accident, mechanical failure, electric shock, or fire.

- Modification of the product is dangerous and must be avoided under any circumstances.



● **Do not use hot or boiling water at a temperature of 60°C or higher.**

Do not use water at a temperature of 60°C or higher. Deformation or damage to the basin, shower head, or tap may result.

Safety Precautions (to be strictly observed)

CAUTION

When using or cleaning the product ...



● **If the covers are damaged, discontinue use of the product.**

If the covers are damaged, immediately contact your local authorised Takara Belmont dealer to request replacement. Failure to do so may result in mechanical failure or an accident.

● **Do not drink the water, hot or cold, from the product.**

This product is intended for washing hair. Do not drink the water, hot or cold, produced by the product.

Depending on the water quality, it may cause diarrhoea or a stomachache.

● **If the plating on the fittings is peeling, discontinue using them.**

If the plating on the faucet fittings (the tap or the thermostatic control knob) is peeling, immediately contact your local authorised Takara Belmont dealer to request replacement. Failure to do so may result in injury.

● **Do not apply impact to the product.**

Damage to the covers or injury due to malfunction or damage of the product may result.

● **When the shower head is in the shower head holder, do not allow water to gush out.**

The water may spill outside the basin or splash onto the client.

If you want to turn on the shower with the shower head placed in the shower head holder, check your surroundings and turn the tap slowly.

● **Do not use the product in locations where freezing is expected.**

The parts may become damaged, causing a water leak.

In the event of damage caused by freezing, repairs will be charged even during the warranty period. If there is a risk of freezing, heat the place to make sure the room temperature does not drop to 0°C or below.

● **Do not use abrasives.**

Do not use abrasives to clean the shower head, shower head holder, or covers.

Use of abrasives, abrasive sponges, or hard cleaning tools such as metal or nylon scrubbers may leave scratches.

● **Do not use the product outdoors.**

This product is for indoor use only. Do not install it outdoors or in a vehicle.

If used outdoors, the product may not work properly or may become damaged.



● **Always operate the power switch section and heater switch(es) (AY-SCES2P*, AY-SCSB2*) by hand.**

With the exception of the foot switch, switches and buttons must always be operated by hand. Operation other than by finger may cause damage or accidental operation.

● **While reclining or raising the backrest, support the client's head with your hand.**

When reclining or raising the backrest, let the client know, and support the client's head with your hand. Otherwise, the client may hit their head on the basin.

● **If the floor is wet, be sure to wipe it dry.**

After shampooing, if the floor is wet, wipe it dry immediately. Otherwise, the floor surface may deteriorate or mechanical failure may result.

Safety Precautions (to be strictly observed)

CAUTION

When using or cleaning the product ...



● Handle the shower hose with care.

- When using the basin, make sure the shower hose is not pinched by your feet or the stool. Otherwise, the basin may become damaged.
- Do not straddle the shower hose during operation. It may become caught on the basin, causing injury.

● Control the heater(s) carefully. (AY-SCES2P*, AY-SCSB2*)

The client may feel hot depending on their physique and clothing. While using the heater(s), check the warmth and the client's condition. If it is too warm, turn off the heater switch(es).

● When working between the chair and the basin, be aware of your surroundings.

If you are carrying metal objects such as scissors while performing treatment, they may scratch the backrest or the basin.

● Be careful of the step created by the base plate.

The base plate creates a step about 9 mm from the floor. Be extra careful not to trip. You may trip over and become injured.

● Be careful with the foot switch cord.

When the client gets on or off the chair, be extra careful not to let the client get caught on or step on the foot switch cord. Otherwise, the client may fall and become injured, or the product may become damaged.

● Be careful with the power cord.

If a power cord is connected to the built-in outlet, be extra careful not to let the client get caught on or step on the power cord when they get on or off the chair. Otherwise, the client may fall and become injured, or the product may become damaged.

● Turn off the power switch after use.

Accidentally touching the foot switch may cause the chair to move unexpectedly, resulting in injury or damage.

● Before use, confirm that each part can be operated normally.

Carefully and routinely inspect for any looseness, backlash, inclination, vibration, noise, temperature, odour, etc.

If you notice anything strange, immediately stop using the product, turn off the power switch, disconnect the power plug, and contact your local authorised Takara Belmont dealer.

● Precautions for cleaning

Some metal parts and mechanical sections of the product have sharp edges. Take care not to injure your hands or fingers during cleaning.

Precautions for Use

- **Use the equipment for hairdressing and esthetic services only.**

This product is an industrial appliance for use in hairdressing salons and aesthetic salons. The product must only be used by professionals such as hair stylists and aestheticians. In addition, this product is manufactured for the purpose of backwash shampooing, side wash shampooing, and head spas. Do not use it for front wash shampooing, facials, shaving, décolleté massages, hand care, foot care, or nail care.

- **Maximum lifting capability (human body) is 1350 N (135 kgf).**

When the maximum lifting capability has almost been reached, it may take more time for the seat to go up.

- **Do not apply heat.**

Deterioration or discolouration may result.

- **Do not apply steam directly to the leather.**

When using a steamer for treatments such as a head spa, make sure the steam does not come into direct contact with the leather. Deterioration of the leather may result.

- **Do not cause a sharp object to come in contact with the leather.**

If a sharp object, such as a pair of scissors, comes in contact with the leather, the leather may tear.

- **Do not place objects other than a person on the seat.**

Deformation, tearing, and/or corrosion of the leather may result.

- **Do not try to forcefully lift the seat, backrest, or leg rest.**

Malfunction or mechanical failure of the chair may result.

- **If a chemical solution gets on the product, wipe it off immediately.**

If a chemical solution gets on the leather or covers, wipe it off immediately. Deterioration or discolouration may result.

- **Do not use strong acid or strong alkaline cleaning agents.**

For cleaning the drainage pipe, do not use cleaning agents containing caustic soda (NaOH) or caustic potash (KOH) as their main ingredients. Also, never pour thinner, alcohol, nail polish remover, gasoline, or kerosene down the drainage pipe. The drain hose may become damaged.

- **After use, be sure to wipe moisture off all parts of the product other than the basin.**

If moisture is left unwiped, it may cause mechanical failure of the product or leave unremovable stains.

- **Lower the seat to the lowest position at the end of each work day.**

When you are done working for the day, simply lower the seat to the lowest position. This position does not exert stress on the product's mechanical parts, thereby extending their life.

- **Do not spray water onto the shower head holder.**

Do not point the shower at the shower head holder. A water leak may result.

- **Return the shower head to the shower head holder so that the shower head plate faces the basin.**

Return the shower head to the shower head holder so that the shower head plate faces the basin. Otherwise, when you turn on the shower, the water may spill outside the basin or splash onto the client.

- **Do not apply excessive force to remove the shower head holder cover.**

This may exert stress on the assembled parts and damage them.

Precautions for Use

- **When keeping water in the basin, be careful not to let the water spill.**

When keeping water in the basin, make sure the designated maximum water level is not exceeded. [See page 30.]

- **Insert the shower head fully into the shower head holder.**

If the shower head is inserted part way, it may not be held securely in the shower head holder, causing the shower head to change direction when water comes out, and splashing water on the client.

- **Do not touch the hot water pipe.**

The hot water pipe is hot. Do not touch it with your bare hands.

- **Keep the temperature of the hot water supplied to the equipment at 80°C or lower.**

Otherwise, the equipment may not work properly or may break down.

- **In cold regions, take measures to drain the water.**

If you are using the product in a cold region during the winter, be sure to take measures against freezing: remove the maintenance cover and loosen the strainer on each check valve to drain the water. Otherwise, water leakage may result.

- **Be sure to attach the neck cushion.**

Be sure to attach the neck cushion. Treatment without the neck cushion attached may put strain on the client's neck, causing injury.

- **Do not use peppermint oil or aromatic oils.**

Do not use peppermint oil, which contains menthol, or aromatic oils on this product. Damage may result to the plastic parts such as the shower head, shower head holder, shower hose, tap, thermostatic control knob, neck cushion, neck base, neck core, hair catcher, or drain cap. In addition, deterioration of the leather on the backrest, seat, leg rest, or lumbar cushion may result.

- **Do not drop heavy objects onto the basin.**

Do not place or drop heavy objects in the basin. Damage such as scratches or cracks may result.

- **Do not strike the top surfaces (caps) of the plastic knobs with objects.**

Do not strike the plastic tap or the thermostatic control knob with hard objects. The plated surfaces may be scratched, crack, or peel, resulting in injury.

- **Close the tap firmly.**

After use and at the end of work, be sure to turn the tap fully clockwise to turn off the water securely. If the water is not completely turned off, a water leak may result.

- **Do not leave the shower head submerged in the water kept in the basin.**

If water pipe pressure drops due to water outage during construction, the water in the basin may back up.

- **When the drain cap is not in use, leave the drain open.**

After work, do not block the drain with the drain cap, a towel, or a shampoo cape.

If the water is accidentally turned on or an increase in water pressure late at night causes a small amount of hot or cold water to come out, the basin may overflow, causing a water leak. When not in use, the drain cap must be removed from the drain and kept outside the basin.

- **Clean the hair catcher frequently.**

Clean the hair catcher as often as possible. If possible, clean the hair catcher after each client's shampooing. If you continue to use the hair catcher in an uncleaned state, the drain will become clogged with accumulated hair, causing water to overflow and become unsanitary.

Precautions for Synthetic Leather Care

● Specifications of the synthetic leather used for this product

[Common to ESPOIR 2, SUITE 2, and NOBLE 2]

For design purposes, there are gathers (folds) in the leather. Due to the manufacturing process, the gathers may vary in width, length, and spacing. Soft padding is used to give volume to the seat upholstery. The folds may spread over many years of use and depending on the conditions of use.

[SUITE 2]

The leather used for SUITE 2 has fine irregularities on the surface, making it non-slip. Also, because of the matte surface, any dirt that adheres to it can be very noticeable.

[NOBLE 2]

The leather used for NOBLE 2 replicates the texture of genuine leather, and is slippery. Also, the white material under the leather may be visible through the thread holes in the seams.

[Lumbar cushion for SUITE 2/NOBLE 2]

Due to the comfort-focused material and manufacturing process, there may be irregularities in shape near the seams.

● Stains from garment dyes

Clothing or belt colourings or dyes may discolour the synthetic leather of this product upon contact. If such colour transfer occurs, wipe with a soft cloth moistened with neutral detergent diluted about tenfold with water, then wipe with a cloth moistened with water, and finally carefully wipe with a dry cloth as quickly as possible to avoid further penetration.

● Precautions against deterioration or colour transfer due to contact

- Contact with other plastic parts or coated products, solvents, adhesive tapes, etc. may cause change in gloss, cracks, deformation, or delamination of the surface.
- Contact with newspaper or other printed matter may cause colour staining.
- Contact with printed fabrics, such as T-shirts, or jeans, etc. may cause colour staining of the leather due to dyes.
- If benzine, nail polish remover, alcohol, or oil comes in contact, discolouration, surface dissolution, change in gloss, hardening or softening, or delamination may occur.
- Using bleach or sheets washed in bleach may cause change in gloss or discolouration.
- If this product is placed in proximity to an extremely high-temperature heat source, such as an iron or a heater, deformation or discolouration may occur.
- Avoid direct sunlight by using curtains, etc. Otherwise, surface changes, contraction, discolouration, fading, etc. may occur.
- Placing a heavy object on the synthetic leather for extended periods may cause permanent dents or wrinkling.

Precautions for Use of Basin Products

The basin for this product is ceramic. Please note that due to unavoidable bending and deformation in the ceramic molding process, there are some variations in the neck position, height, shape, and weight between individual basins. Also, due to the nature of ceramics, pouring boiling water into the basin will cause the affected part to expand rapidly, which may cause cracks in the surface. Do not pour boiling water on the ceramic basin. The basin may be damaged, leading to injury or causing the water to leak into the upper unit, resulting in rust.

Precautions for Use of Resin-plated Parts

● **The tap and thermostatic control knob for this product are resin-plated.**

- Plating is a thin, hard metal film that may crack or peel in the surface due to corrosion or deterioration over time.
- Impact from falling objects may cause scratches or cracks on the plated surface.
- If hit with something hard, the plated surface may become scratched or cracked.
- Scratches or cracks on the plated surface may develop into peeling of the plating.

CAUTION

Make sure there are no scratches, cracks, or peeling on the plated surfaces of the tap and the thermostatic control knob. If the plating is peeling, immediately discontinue use of this product and contact your local authorised Takara Belmont dealer. Failure to do so may result in injury.

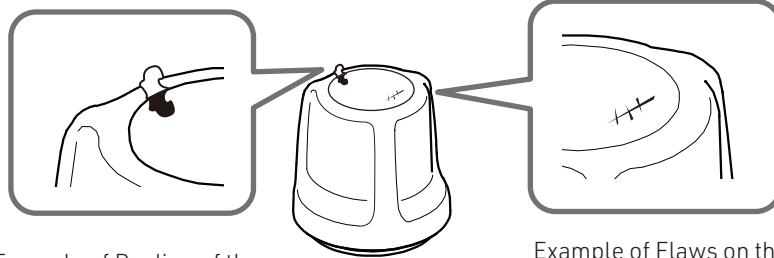

Example of Peeling of the Plated Surface

Example of Flaws on the Plated Surface

Warning Label Locations

WARNING
Risk of Pinching!

CAUTION
Drain Outlet Drain Cap
The drain cap must be detached from the drain outlet when the product is not in use.

CAUTION	CAUTION	CAUTION
⊘	!	⊘
Do not use hot water of 60°C and higher. Using hot water at 60°C and higher may deform or damage the ceramic bowl, the shower head or the faucet handle.	If chemical such as hair dye attached to the equipment, wipe it out immediately, or it may cause discoloration or deterioration.	Do not use chemical detergent mainly containing caustic soda (NaOH) & caustic potash (KOH) for cleaning drain pipes, etc. This may cause damage on the drain hose, etc.
For other cautions, please read the operating instruction carefully before use.		

WARNING
PINCHING
DO NOT insert finger or hand into this space.
Serious injury may occur by pinching.

Before Using the Product ...

- The back wash basin is a shampooing device designed for backwash shampooing*1 and head spa treatments.
- The side wash basin is a shampooing device designed for side wash shampooing*2 and head spa treatments.
- The back approach*3 to this product assumes the user is sitting during treatments.
For treatments in a more comfortable posture, use of the ESPOIR stool (sold separately, model number ES-ESST) is recommended.
- Make sure the accessories have been properly attached to the product.
- Please note that the gap between covers may vary slightly from product to product.
- There is a small gap between the basin and the cover. This is because the basin is made of ceramic, and is not indicative of defective quality.
- Please note that the gap between the basin and the reclined backrest may vary slightly from product to product.

*1 Backwash shampooing: The user performs shampooing from behind the basin (in the back position).

*2 Side wash shampooing: The user performs shampooing while standing to the side of the basin (in the side position).

*3 Back approach: The user performs head spas and other treatments from behind the basin.

Accessories

Hair catcher...1



Drain cap...1

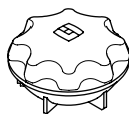

Neck cushion...1

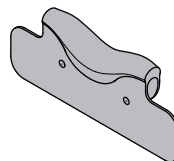

Head cushions...1 pair

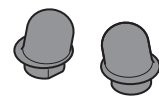

Installation Instructions...1

Operating Instructions...1

Information Regarding Regularly Replaced Parts...1

Part Names

The products described in this document consist of a basin body and a chair. (A chair consists of a chair body and a seat body.)

- There are predetermined combinations for a chair (combinations of a chair body and a seat body).
- A basin body with either a back wash basin or a side wash basin can be combined with a chair (consisting of a chair body and a seat body).
- The basin body and the chair body need to match in height (H or M).

Basin body

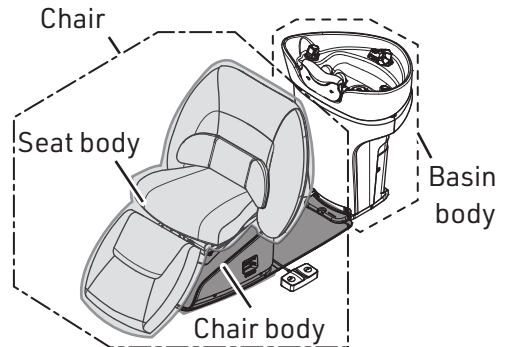
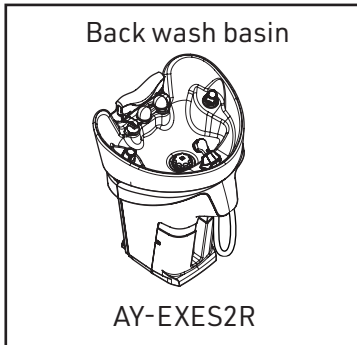

Chair (a chair body and a seat body)

Product name	ESPOIR 2 Basic	ESPOIR 2 Premium	SUITE 2	NOBLE 2
Heater(s)	None	Leg rest heater	Leg rest heater and backrest heater	
Movable leg rest type	Seat body: AY-UES2B Chair body: AY-SCES2B	Seat body: AY-UES2P Chair body: AY-SCES2P	Seat body: AY-USI2 Chair body: AY-SCSB2	Seat body: AY-UNB2 Chair body: AY-SCSB2

Part Names

ESPOIR 2 Basic

ESPOIR 2 Premium

SUITE 2

NOBLE 2

Backrest heater
(SUITE 2 and NOBLE 2 with heater(s))

Lumbar cushion
(SUITE 2, NOBLE 2)

Leg rest heater
(ESPOIR 2 Premium, SUITE 2,
and NOBLE 2 with heater(s))

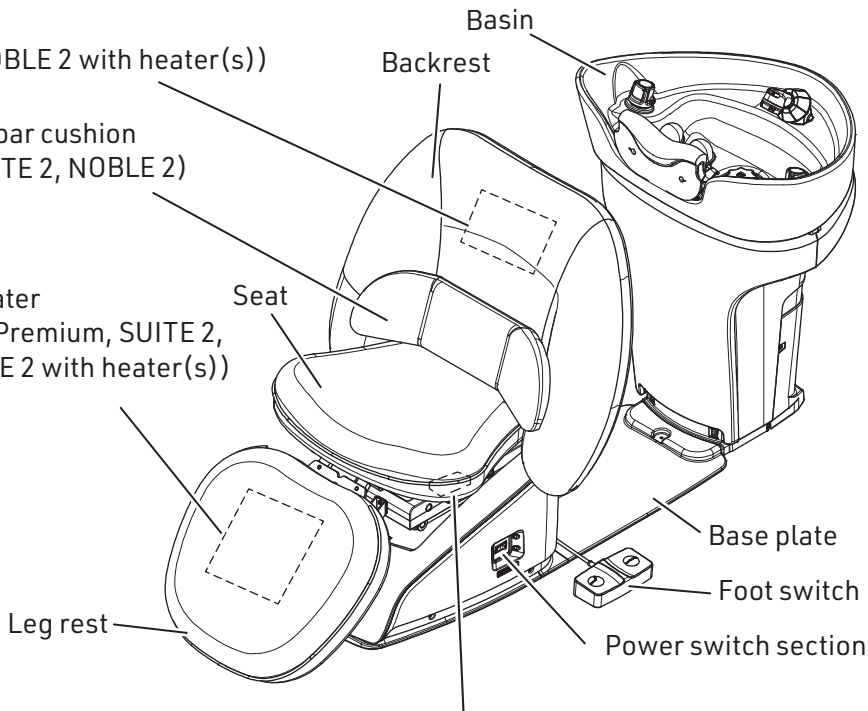

Heater switch(es) (ESPOIR 2 Premium, SUITE 2, and NOBLE 2 with heater(s))

The external covers are made of plastic. There may be streaked lines or areas of a different shade. They occur during the manufacturing process, and they are not indicative of a product defect or defective quality.

Back wash basin

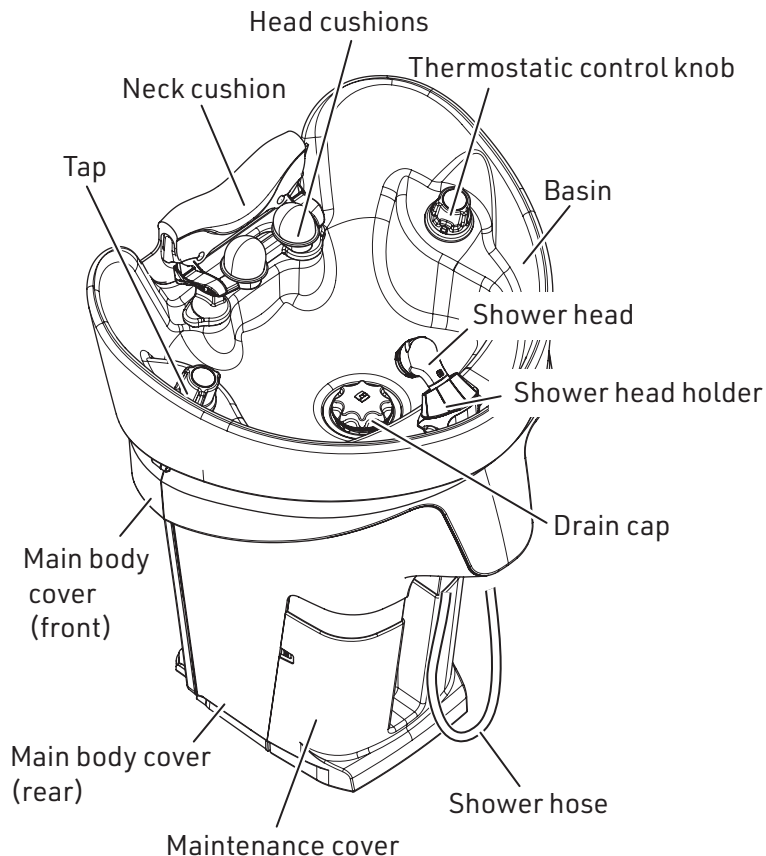

Part Names

Shower head holder

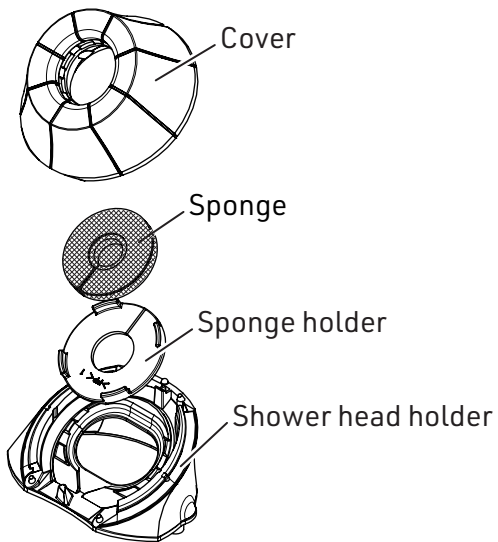

Power switch section

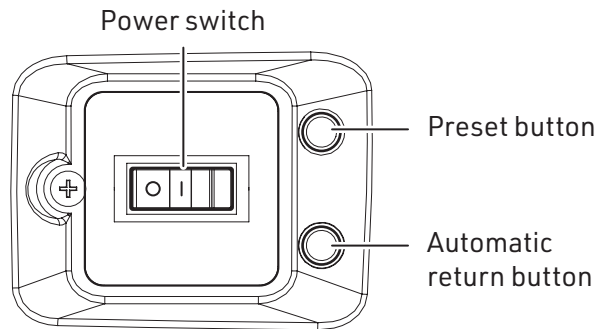

Foot switch

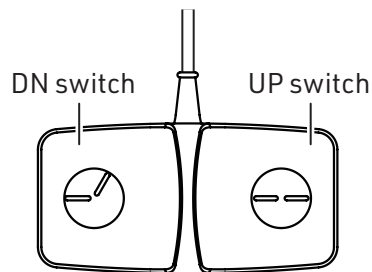

Shower head

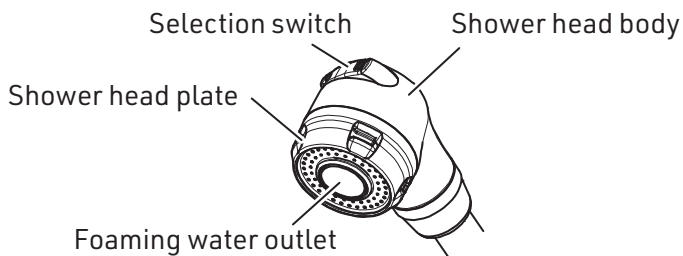

Heater switch(es)

ESPOIR 2 Premium

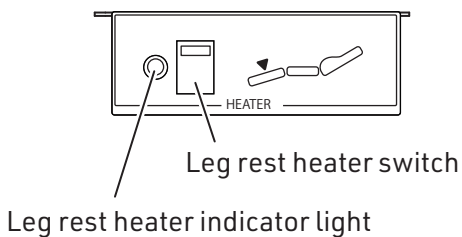

SUITE 2

NOBLE 2

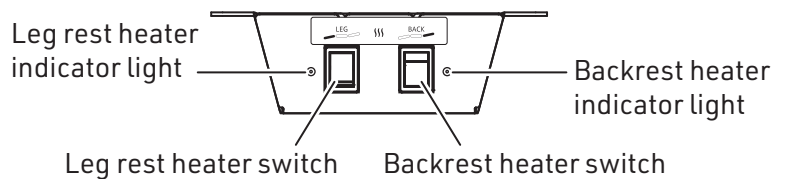

Attaching/Removing the Neck Cushion

Back wash basin

■ Attaching the neck cushion

- 1 Orient the neck cushion as shown in the illustration, and fit it onto the attachment fittings.**

Make sure the neck cushion is oriented properly.

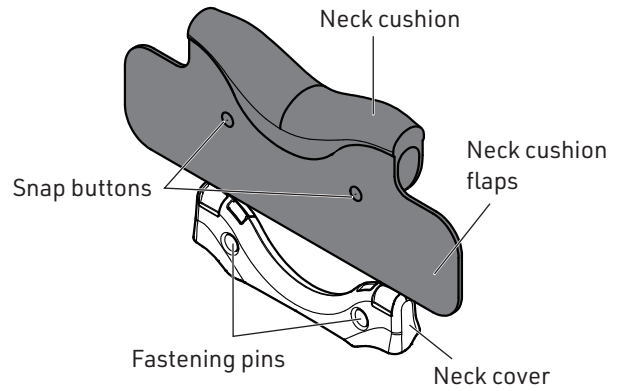

- 2 While straightening up the neck cushion, attach the snap buttons on the neck cushion to the fastening pins on the neck cover. (Four locations, two on the front and back)**

The fastening pins are removable. Be careful not to lose them.

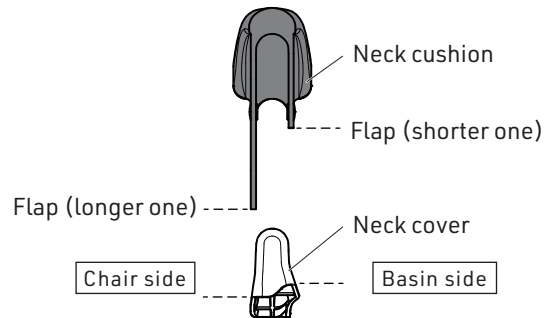

- 3 Fit the neck cover onto the two bars.**

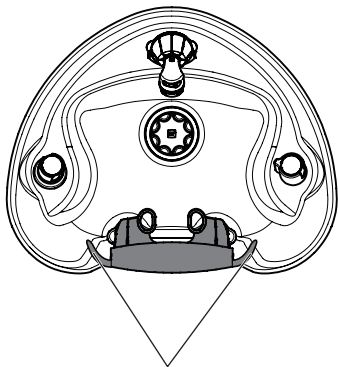

Neck cushion flaps fitted inside the basin

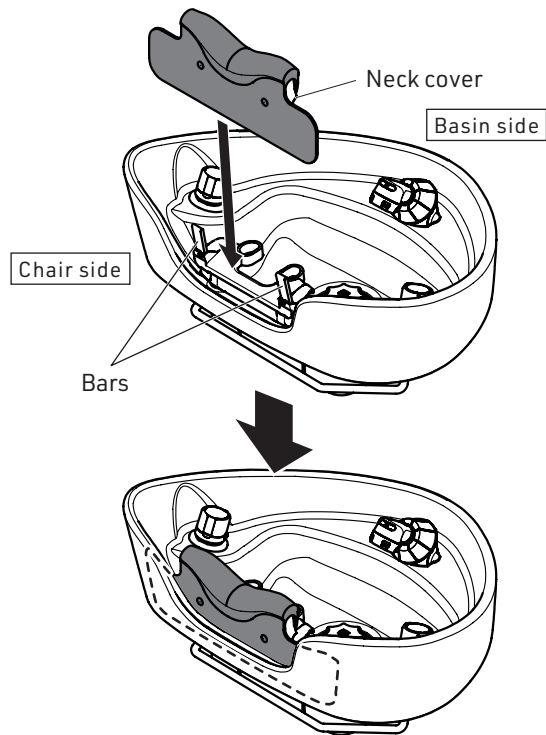

■ Removing the neck cushion

- 1 Remove the neck cushion (with the neck cover) from the bars.**
- 2 Unfasten the snap buttons (four locations). Remove the neck cushion from the neck cover.**

Make sure the neck cushion fits entirely inside the basin (as shown by the dashed line).

⚠ CAUTION

Do not apply excessive force to remove the neck cushion. Damage to the parts may result.

Attaching/Removing the Neck Cushion

■ Removing the neck cushion

- 1 Remove the neck cushion (with the neck core) from the neck base.**
- 2 Unfasten the snap buttons (two locations). Remove the neck cushion from the neck core.**

CAUTION

Do not apply excessive force to remove the neck cushion. Damage to the parts may result.

The neck cushion is a consumable.

When it becomes noticeably dirty or deteriorates on the surface, replace it (for a charge).

To replace the neck cushion, contact your local authorised Takara Belmont dealer.

Attaching the Head Cushions

Back wash basin

Align the head cushions with the attachment fittings as shown in the illustration, and fit them in.

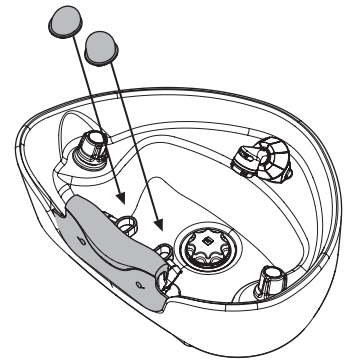
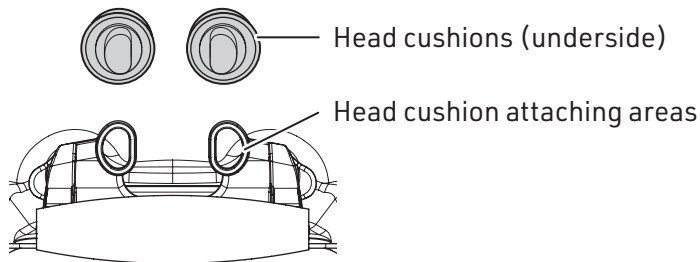

Head cushions are consumables.

When they become noticeably dirty or deteriorate on the surface, replace them (for a charge).

To replace the head cushions, contact your local authorised Takara Belmont dealer.

Attaching the (Optional) Inner Tray

Back wash basin

Pass the shower head holder through the hole in the inner tray as shown in the illustration to attach the inner tray to the basin.

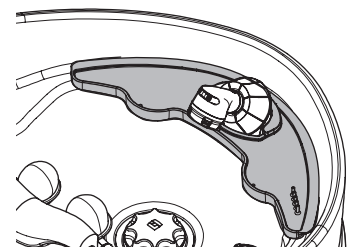
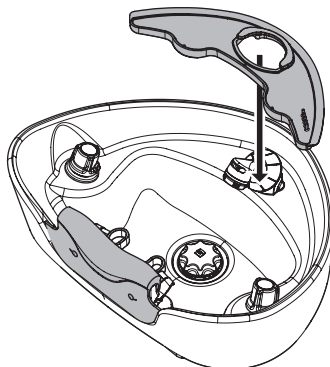

Using the Lumbar Cushion

SUITE 2

NOBLE 2

When using the lumbar cushion, place it in the position and orientation shown in the illustration on the right.

CAUTION

The lumbar cushion sags easily and sometimes gets stuck in the space between the seat and the backrest. After each treatment, place the lumbar cushion back in the position shown in the illustration on the right.

Front

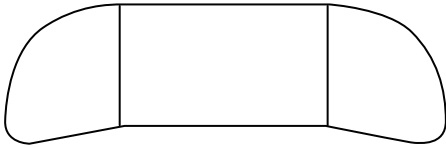

Back

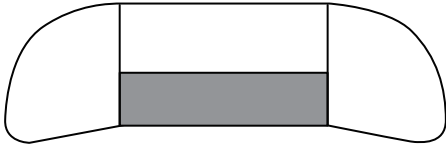

Lumbar cushion
(placed with the front
side facing the front)

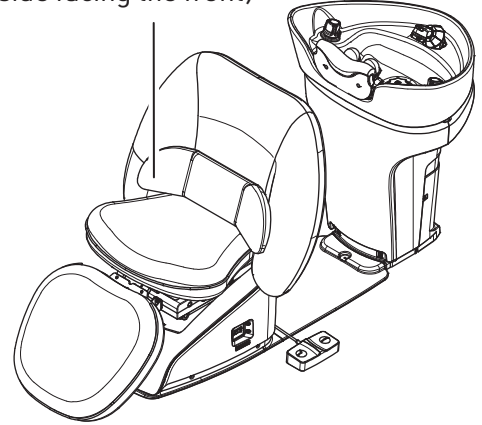

Turning on the Power

The power switch is on the left side of the chair when viewed from the basin. Pressing the right side (marked 'I') of the power switch will turn the power ON. Pressing the left side (marked 'O') will turn the power OFF.

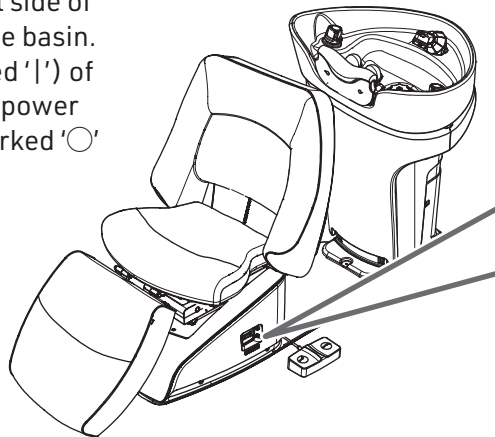

Power OFF

Power ON

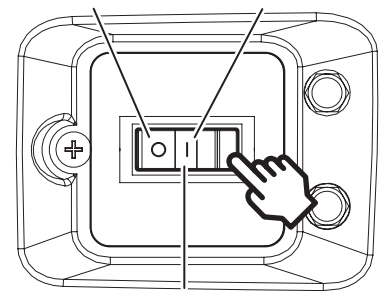

Power switch

WARNING

- Make sure to turn off the power switch when the product will not be in use for a long time, such as at the end of each work day.
- Make sure to turn off the product at the switchboard when the product will not be used for an extended period of time, such as before holidays. Otherwise, the insulation may deteriorate, causing fire due to electrical leakage, electric shock, or burns.

CAUTION

- Operate the power switch with your finger.
- When turning on the power switch, make sure you are not accidentally pressing an operation switch. Otherwise, the preset position or other settings may change.

Lifting/Lowering the Seat

The seat can be lifted and lowered in two ways: by automatic and manual operation.

Automatic operation... [Preset] The seat goes up to the preset position and stops automatically.

[Automatic return] The seat goes down to the initial position and stops automatically.

Manual operation... You can fine-tune the seat height.

When the automatic operation begins, a beep sounds for confirmation.

* This confirmation beep cannot be turned off.

Lifting and lowering the seat (automatic operation)

[Preset]

Lifting the seat to the preset position

Step on the UP switch.

Press and hold the switch (step on it for one second or more), and a beep will sound, and automatic operation will begin to move the seat to the preset position.

[Automatic return]

Lowering the seat to the initial position

Step on the DOWN switch.

Press and hold the switch (step on it for one second or more), and a beep will sound, and automatic operation will begin to move the seat to the initial position.

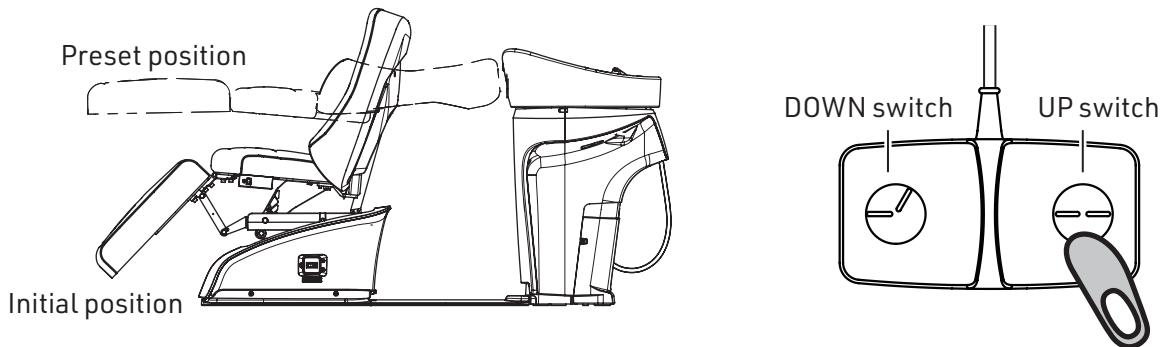

- The speed at which the seat moves up and down differs depending on whether or not there is someone on the seat.
The seat is set to move up and down at the most appropriate speed when a person is seated on it. When there is no one on the seat, the seat moves up faster and moves down more slowly.
- The seat is hydraulically driven, so the speed at which the seat moves up and down also differs depending on seasonal changes in oil temperature and the weight of the client sitting on the seat. The higher the atmospheric temperature, the faster the seat will move down, and the lower the atmospheric temperature, the slower the seat will move down. The heavier the client, the faster the seat will move down, and the lighter the client, the slower the seat will move down.
- Once automatic operation has started, the chair will continue to operate after you take your foot off the foot switch.

<Preset position>

The preset position is set at the time of shipment from the factory to provide the client with an appropriate lying posture, but the client's lying comfort will vary depending on their physique and posture. To adjust the preset position for a specific client, follow the instructions under 'Changing the Preset Position' [page 24].

Lifting/Lowering the Seat

Stopping the automatic operation midway

During automatic operation, you can stop the chair from moving by stepping on either the UP or DOWN switch.

When lifting or lowering the seat, make sure there are no people or obstacles near the chair. Otherwise, injury or damage to the chair may result.

- Always make sure there are no people or obstacles between the backrest and the basin. **Be careful particularly when small children are around the product.**
- Make sure there are no people, pets, or obstacles between the chair and the floor.
- When lifting or lowering the seat, make sure there will be sufficient space between the client's feet and the wall ahead.
- When working between the chair and the basin, never touch the foot switch. You may get caught and become injured.

WARNING



Adjusting the seat height (manual operation)

(1) To lower the seat slightly, press the DN switch briefly (for less than one second).

(2) To lift the seat slightly, press the UP switch briefly (for less than one second).

* Repeat until the seat reaches the desired height. Please note that if you step on the switch for one second or more, automatic operation will begin.

* The seat cannot be lifted higher than the preset position set at the time of shipment from the factory.

Changing the Preset Position

The preset position is pre-adjusted at the factory before shipment to the standard position. To change the preset position, follow the steps below.

- 1 With the UP/DOWN switch, bring the seat to the desired height to which you want to change the preset position.**
- 2 Turn off the power switch temporarily.**
- 3 After five seconds, press the preset button, which is to the upper right of the power switch, and while holding it down, turn on the power switch and wait for five seconds until a setup beep sounds. [Setup complete]**

* If you do not hear the setup beep, the setup is not complete, so repeat steps 2 and 3.

* Depending on the characteristics of the chair and the operating environment, the actual preset position may differ slightly from the newly set position. After completing the setup, check that the seat moves to the new preset position: first, use the automatic return function to return the seat to the initial position, and then bring the seat to the preset position.

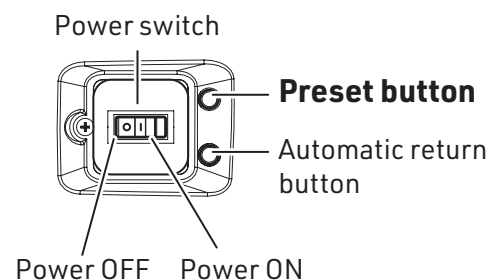

Changing the Preset Position

- * The automatic return button is only used when the chair is repaired. Refrain from pressing the automatic return button as this may cause a setting malfunction.
- * The preset button and the automatic return button are not operation switches. These buttons will not move the chair.

Using the Shower Head

You can switch between shower mode and low-splash mode by flipping the selection switch.

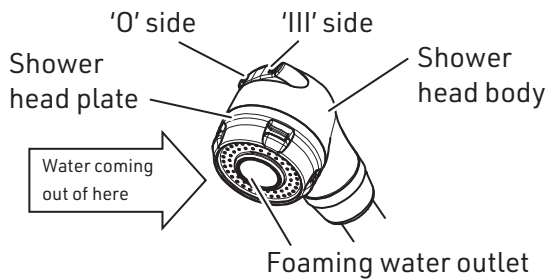

<Shower mode>

- Press the 'III' side of the selection switch.



<Low splash mode>

- Press the 'O' side of the selection switch.

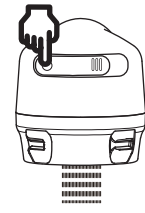

CAUTION

- When the shower head is in the shower head holder, do not let water gush out. The water may spill from the basin, and mechanical failures of the product or damage to the floor may result.
- After using the shower head, return it to the shower head holder. When returning it to the shower head holder, make sure the shower head plate faces the basin.
- Do not pull the shower hose with excessive force. Damage to the shower hose or a water leak may result.

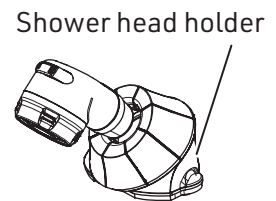

Using the Tablet Case (Optional)

1 Press the 'III' side of the selection switch on the shower head to switch to shower mode.

2 Make sure the gasket (black) is in the tablet case.

3 Place a carbonation tablet (sold separately) in the tablet case.

Use Takara Belmont-specified carbonation tablets only.

4 Attach the tablet case to the shower head.

Align the protrusion on the shower head with the shape of the tablet case, and turn the tablet case clockwise to attach it.

5 After use, remove the tablet case from the shower head.

Turn the tablet case counterclockwise to remove it.

When you use the tablet case, switch to shower mode. In low-splash mode, using the tablet case will decrease the flow rate.

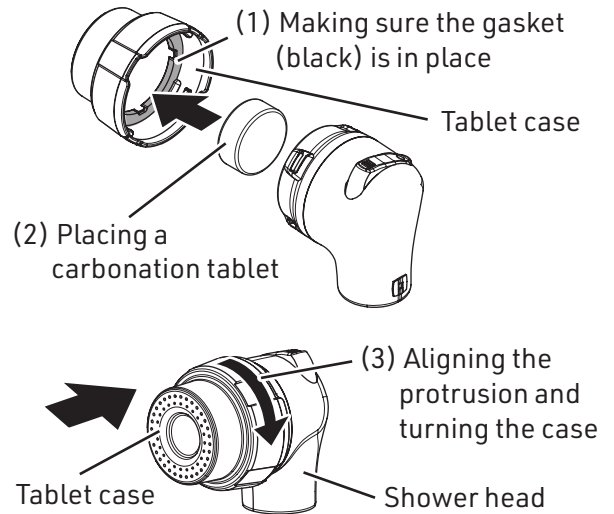

If the treatment time is too short, the tablet may not dissolve completely. Also, some coagulated components may remain undissolved, but this is not indicative of defective quality.



CAUTION

After use, remove the tablet case. While the tablet case is attached, the low-splash mode is not available.

Adjusting the Flow Rate

Turning the tap to the left (counterclockwise) will make hot water come out of the shower head. The more you turn it to the left, the higher the flow rate will be.

Turning the tap all the way to the left will bring the flow rate to the maximum.

Turning the tap all the way to the right (clockwise) will stop the water.

Dripping water from the shower head is not indicative of abnormality. It is just the residual water being discharged from inside the shower head.

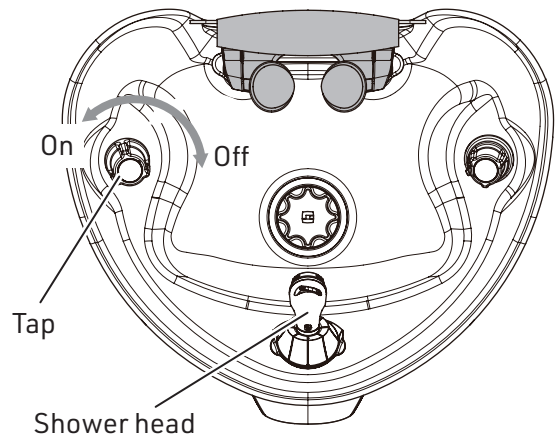

CAUTION

- When the basin is not in use, firmly turn the tap all the way to the right (clockwise) to stop the water securely. If the water is not completely turned off, a water leak may result.
 - After work, do not block the drain with the drain cap, a towel, or a shampoo cape. If the water is accidentally turned on or an increase in water pressure late at night causes a small amount of water to come out, the basin may overflow and cause a water leak.
 - If wastewater does not drain away smoothly, the drainage pipe may be clogged. Stop using the product and contact your local authorised Takara Belmont dealer.
 - Before operating the tap, remove any metal items such as your rings or watch. Otherwise, the metal items may hit the top surface (cap) of the tap, leaving scratches or cracks on the plated surface and causing the plating to peel off.
 - Make sure there are no scratches, cracks, or peeling on the plated surface of the tap.
- If the plating is peeling, immediately discontinue use of this product and contact your local authorised Takara Belmont dealer. Failure to do so may result in injury.

- Depending on the operating environment and conditions, the sound of running water may be heard from the basin body.
This phenomenon is not indicative of a defect of the equipment. It occurs when hot or cold water rushes down the plumbing due to high water pressure or flow rate. Adjusting the water pressure may reduce the sound of running water.
- Depending on the operating environment and conditions, more force may be required to turn the tap.
This is due to deterioration of the gaskets and other components of the moving parts, or decrease in grease over time, and it will be necessary to replace the gaskets or apply grease.
To request such adjustment or replacement services (for a charge), contact your local authorised Takara Belmont dealer.

Adjusting the Water Temperature

- (1) Turn the thermostatic control knob in the 'H' or 'C' direction to set the temperature appropriately. Turning it in the 'H' direction will make the water hotter, and turning it in the 'C' direction will make the water colder.

CAUTION

Before adjusting the hot water temperature, reduce the flow rate and point the shower head away from the client. Then, adjust the temperature while checking it with your hand. Very hot water may flow out, so be careful about the operation.

- (2) If you continue to turn the thermostatic control knob in the 'H' direction, it will not turn beyond the position shown in the illustration on the right (the thermostatic control lock position). You may want to turn it beyond this position to use hotter water (above about 40°C). If so, while holding down the stopper button on the thermostatic control knob, turn the knob in the 'H' direction, and the water will become hotter.

* Set your water heater's hot water supply temperature to at least 10°C higher than the shower head water temperature.

* This equipment is designed not to dispense hot water above about 49°C.

(The values above assume that the water supply pressures are the same and that the cold and hot water supply temperatures are 20°C and 60°C, respectively. It depends on the actual water heater and plumbing environment.)

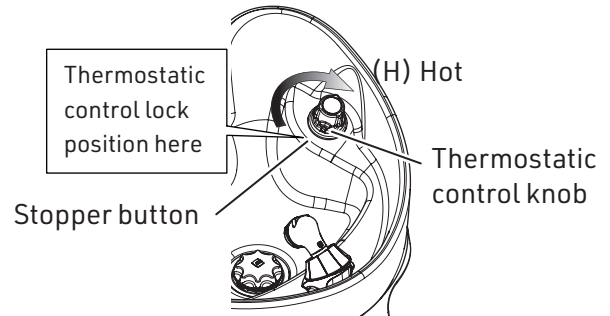
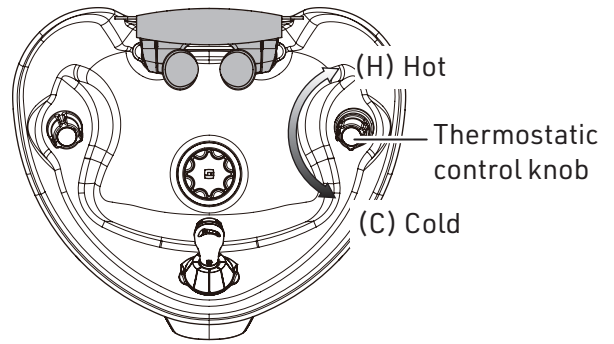

WARNING

- Before turning on the water, check the temperature setting of the thermostatic control knob. Otherwise, very hot water may come out, causing burns. Also, if you shampoo the client's hair at a high temperature beyond the thermostatic control lock position, do not operate the thermostatic control knob during shampooing. You may accidentally turn it more than you want, causing scalding water to splash onto the client's head, and burns may result.
- If you turn the thermostatic control knob beyond the thermostatic control lock position, be sure to return it to the thermostatic control lock position after use. Failure to do so may cause scalding water to splash onto your hands and the client's head, resulting in burns.

CAUTION

- Before operating the thermostatic control knob, remove any metal items such as your rings or watch. Otherwise, the metal items may hit the top surface (cap) of the thermostatic control knob, leaving scratches or cracks on the plated surface and causing the plating to peel off.
- Make sure there are no scratches, cracks, or peeling on the plated surface of the thermostatic control knob. If the plating is peeling, immediately discontinue use of this product and contact your local authorised Takara Belmont dealer. Failure to do so may result in injury.

Adjusting the Water Temperature

- Depending on the operating environment and conditions, adjusting the hot water temperature may significantly change the flow rate and the temperature of the hot water. This phenomenon is not indicative of a defect of the equipment. It occurs in the following situations: a deviation from the recommended hot water supply temperature (60° C to 80° C); high hot and cold water supply pressure; a significant difference in cold and hot water pressure; or simultaneous use of multiple devices.
- Depending on the operating environment and conditions, the hot water temperature at the thermostatic control lock position may not be 40° C (considered as an appropriate temperature), but this is not indicative of abnormality. This lock function is an auxiliary safety feature to prevent very hot water from abruptly coming out due to erroneous operation.
- To request adjustments of the hot water supply temperature, the hot or cold water supply pressure, or the thermostatic control lock position of the thermostatic control knob (for a charge), contact your local authorised Takara Belmont dealer.

Filling the Basin with Hot Water

To fill the basin with hot water, such as for emulsifying hair colouring, turn the drain cap clockwise to cover the drain.

Make sure the water level does not exceed the broken line (---) shown in the illustration below. If you fill the basin beyond this line, the water will spill.

To drain water kept in the basin, turn the drain cap counterclockwise to open the drain, and the water will be drained.

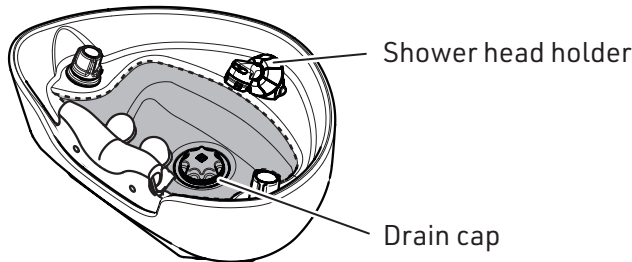
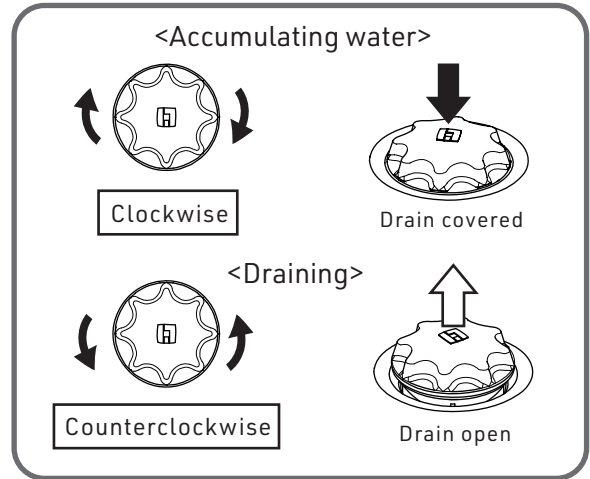

- The water level beyond which the water spills is lower than where the shower head holder is located.

When filling the basin, always make sure the designated maximum water level is not exceeded. [See the illustration on the right.]

- Do not leave the shower head submerged in the water kept in the basin. If water pipe pressure drops due to a water outage or other accident, the water kept in the basin may flow back into the shower head.

[Designated maximum water level]

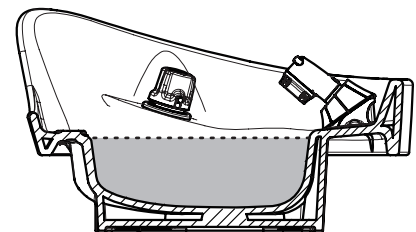

CAUTION

- If wastewater does not drain away smoothly, the drainage pipe may be clogged. Stop using the product and contact your local authorised Takara Belmont dealer.
- When not in use, the drain cap must be removed from the drain and kept outside the basin. If the drain cap is not removed, it may close the drain accidentally, and if water is accidentally turned on and you do not notice it, the basin may overflow and cause a water leak.

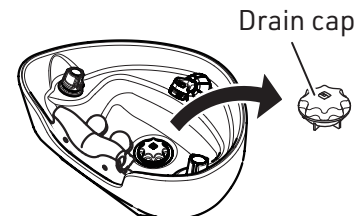

After filling the basin, an amount of water that is too small to affect your work may come out, but this is not indicative of a defect of the equipment. In the event of a significant increase in the amount of water being lost, the drain cap gasket may become deteriorated or worn, so replace the drain cap (for a charge).

Shampooing

1 Return the seat to the initial position.

The seat can be returned to the initial position in the following way:

Press and hold the DN switch on the foot switch (step on it for one second or more), and a beep will sound, and the chair will enter automatic operation, returning the seat to the initial position.

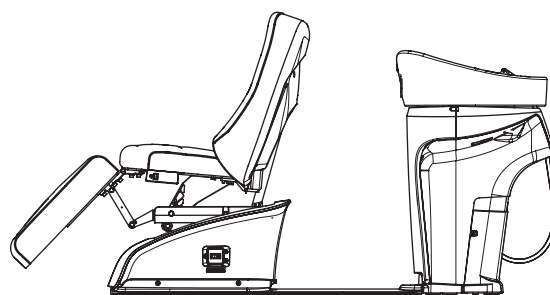

[Initial position]

When the automatic operation begins, a beep sounds for confirmation.

* This confirmation beep cannot be turned off.

WARNING

When lifting or lowering the seat, make sure there are no people or obstacles near the chair. Otherwise, injury or damage to the chair may result.

- Always make sure there are no people or obstacles between the backrest and the basin. Be careful particularly when small children are around the product.
- Make sure there are no people, pets, or obstacles between the chair and the floor.
- When lifting or lowering the seat, make sure there will be sufficient space between the client's feet and the wall in front.
- When working between the chair and the basin, never touch the foot switch. You may get caught and become injured.



CAUTION

Before guiding the client to the chair, always make sure the seat has returned to the initial position.

If you let the client get on or off the seat when it is lifted, damage to the product or injury to the client may result.

2 Instruct the client to sit on the seat from the side.

Instruct the client to first sit on the seat from the side, then face the front, and then sit back.

CAUTION

- When the client sits down, be careful not to let them sit on the edge of the seat. The chair may become damaged.
- Always make sure the client's fingers and clothes and any objects are not in the gap between the seat and the backrest, and that the client is resting their hands on their body or the seat. If any body parts or objects get caught during operation, injury may result.
- Be aware that if the client is wearing specially processed clothing, its colour or pattern may transfer to the leather.

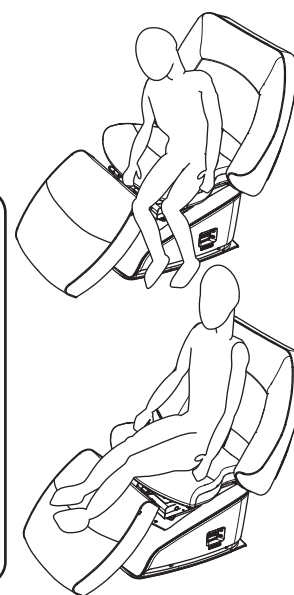

When the client sits down, instruct them to sit back in the seat. If the client does not sit back far enough, their back may shift or you may not be able to guide them into the appropriate position.

Shampooing

3 Put a shampoo cape on the client.

Recommended item: Shampoo cape without a dropper

* If you use a shampoo cape with a dropper, hang the dropper in the gap between the basin and the backrest.

4 Put the client in a lying posture.

Press and hold the UP switch (step on it for one second or more), and a beep will sound, and automatic operation will begin to put the client in a lying posture (preset position). While supporting the client's head, gently lower it onto the neck cushion.

WARNING

When lifting or lowering the seat, make sure there are no people or obstacles near the chair. Otherwise, injury or damage to the chair may result.

- Always make sure there are no people or obstacles under the seat or leg rest. Be careful particularly when small children are around the product.
- Make sure there are no people or objects between the chair and the floor.
- When lifting or lowering the seat, make sure there will be sufficient space between the client's feet and the wall in front.
- When working between the chair and the basin, never touch the foot switch. You may get caught and become injured.

WARNING

When the backrest is reclined, do not let the client get up. If pressure is applied from above to the parts of the backrest where the arms are rested, as shown in the illustration on the right, the backrest will rise due to its design. The client may lose their balance and become injured.

Parts of the backrest where the arms are rested

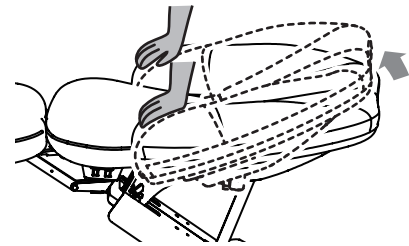
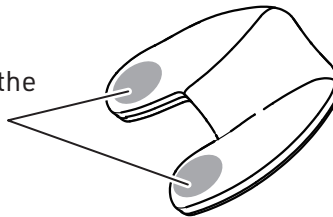

CAUTION

When reclining the backrest, support the client's head with your hand. Otherwise, the client may hit their head on the basin.

- The speed at which the seat moves up and down differs depending on whether or not there is someone on the seat.
The seat is set to move up and down at the most appropriate speed when a person is seated on it. When there is no one on the seat, the seat moves up faster and moves down more slowly.
- The seat is hydraulically driven, so the speed at which the seat moves up and down also differs depending on seasonal changes in oil temperature and the weight of the client sitting on the seat. The higher the atmospheric temperature, the faster the seat will move down, and the lower the atmospheric temperature, the slower the seat will move down. The heavier the client, the faster the seat will move down, and the lighter the client, the slower the seat will move down.

Shampooing

5 Check that the client's face is positioned horizontally.

If their face is not positioned horizontally, ask the client to shift up or down, making fine adjustments.

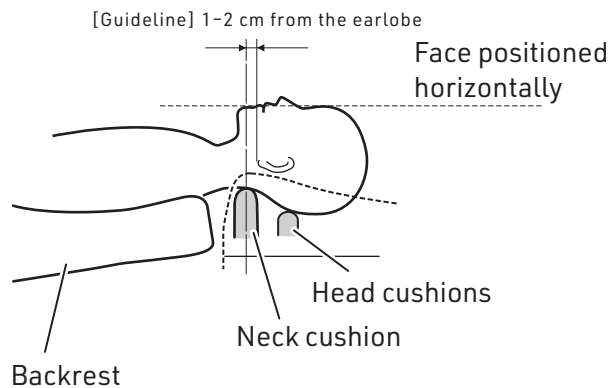

6 Adjust the backrest height as needed.

Press the UP/DN switch briefly (for less than one second) to adjust the backrest height.

Backrest movement for adjustment:

- Briefly pressing the UP switch will lift the backrest while reclining it towards the basin.
- Briefly pressing the DN switch will lower the backrest while raising it away from the basin.

⚠ CAUTION

When adjusting the backrest height, be careful not to activate automatic operation. Pressing and holding the UP or DN switch will activate automatic operation, which may result in injury to the client.

7 Perform the shampooing.

⚠ WARNING

During shampooing, be careful not to let the client or other people touch the foot switch. Failure to do so may cause the chair to be activated, resulting in injury.

Shampoo (treatment) styles

<Backwash shampoo (in the sitting position)>

The user sits behind the basin to perform the shampooing.



<Side wash shampoo>

The user stands next to the basin to perform the shampooing.

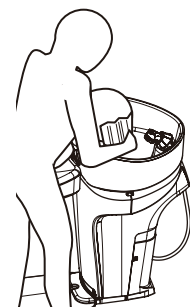

Shampooing

WARNING

When operating the chair, pay attention to the following points:

- When lowering the seat, always make sure there are no people or obstacles under the seat or the leg rest. Be extra careful particularly when small children are around the product.
- When lifting or lowering the seat, make sure there will be sufficient space between the client's feet and the wall ahead.

When performing backwash shampooing (in the sitting position), use the ESPOIR Stool (sold separately, model number: ES-ESST) specifically designed for that purpose.

<How to adjust the seat height of your ESPOIR Stool>

- (1) While sitting on the stool, pull the lever up to unlock the seat.
- (2) Adjust the seat to the desired height.
- (3) Release the lever to lock the seat.

For details, see the Operating Instructions that come with the stool.

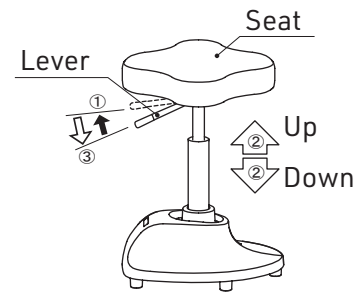

8 After shampooing, return the seat to the initial position.

Make sure there are no people or obstacles within the operating range of the seat and the leg rest. Press and hold the DN switch (step on it for one second or more), and a confirmation beep will sound, and automatic operation will begin to return the seat to the initial position. While the seat is being returned, support the client's head.

WARNING

- Confirm that the seat has returned to its initial position before instructing the client to stand up from the seat. Do not let the client stand up while the seat is still moving. Injury to the client or damage to the equipment may result.
- When lowering the seat, always make sure there are no people or obstacles under the seat or the leg rest. Be extra careful particularly when small children are around the product.
- When lifting or lowering the seat, make sure there will be sufficient space between the client's feet and the wall ahead.

- The speed at which the seat moves up and down differs depending on whether or not there is someone on the seat. The seat is set to move up and down at the most appropriate speed when a person is seated on it.

When there is no one on the seat, the seat moves up faster and moves down more slowly.

- The seat is hydraulically driven, so the speed at which the seat moves up and down also differs depending on seasonal changes in oil temperature and the weight of the client sitting on the seat. The higher the atmospheric temperature, the faster the seat will move down, and the lower the atmospheric temperature, the slower the seat will move down. The heavier the client, the faster the seat will move down, and the lighter the client, the slower the seat will move down.
- If you turn on the hot water when the basin is cold, you may hear cracking sounds coming from the surface of the basin or around the drain. This phenomenon is not indicative of a defect of the equipment. It occurs when the basin or drain expands due to a sudden change in temperature.

Shampooing

9 After use, wipe off any moisture or chemicals that may be on the surfaces.

■ Moisture or chemicals on the main body covers or the outer side of the basin

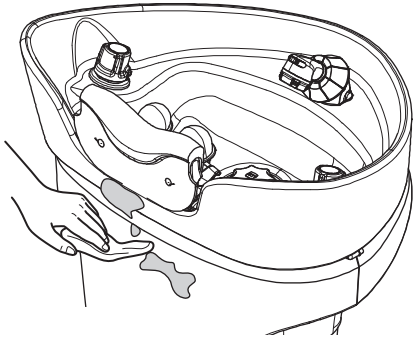

■ Water or chemicals that run down the shower hose onto the floor

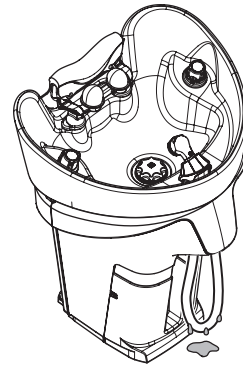

■ Chemicals on the shower head holder

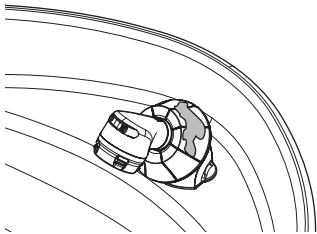

■ Chemicals on the inner tray (optional item)

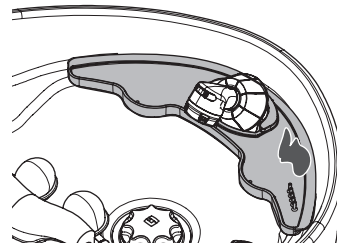

CAUTION

- After use, be sure to wipe any moisture or chemicals off any part of the product other than the inside of the basin. If moisture or chemicals are left unwiped, they may cause mechanical failure of the product or leave unremovable stains.
- If the shower head holder cover is left stained with chemicals (especially those containing oil) over time, it may swell and become easily detached. If the shower head holder cover becomes easily detached, replace it (for a charge). For replacement, see [page 42].
- When not in use, the drain cap must be removed from the drain and kept outside the basin. If the drain cap is not removed, it may close the drain accidentally, and if water is accidentally turned on and you do not notice it, the basin may overflow and cause a water leak.

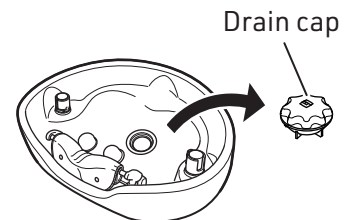

Space between the Chair and the Basin

This equipment allows you to stand between the chair and the basin to perform chemical application or other work from behind the client.

CAUTION

When standing between the chair and the basin for work, take the following precautions:

- Do not lean on the basin while working.
The basin may tip over or your clothes may become stained by the colouring agents on the neck cushion or the basin.
- Be careful to avoid unintended operation of the foot switch.
During work, be careful not to accidentally step on the foot switch. In the event of getting trapped by the backrest, escape from the danger by following the procedure instructed in 'If you are trapped by the backrest'.
- Control the items you are carrying.
If you are carrying metal objects such as scissors during work, they may scratch the basin or backrest.

If you are trapped by the backrest

If you accidentally press the foot switch and end up getting trapped between the backrest and the basin, you can escape by lifting the backrest. If the backrest should fall towards you while you are working between the chair and the basin, quickly escape and stop the automatic operation midway. (See 'Stopping the automatic operation midway' [page 24].)

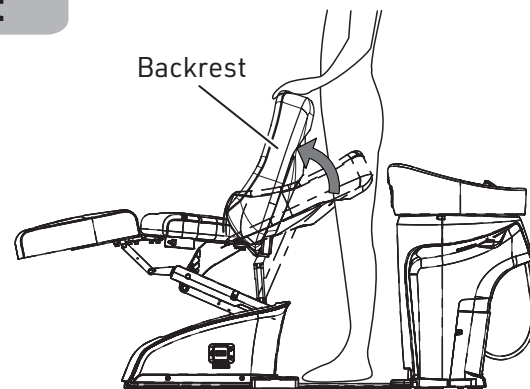

Use the Heater(s)

ESPOIR 2 Premium with heater

The leg rest heater switch is on the lower left side of the seat when viewed from the basin. Pressing the upper side of the switch turns on the lamp and the power of the heater.

Pressing the lower side of the switch turns off the lamp and the power of the heater.

* It takes about 10 minutes for the surface to warm up after you turn on the power. (The time varies depending on the ambient temperature.)

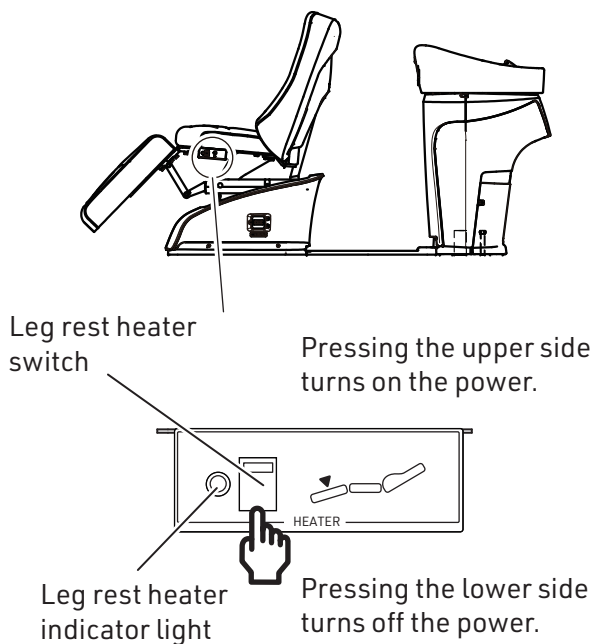

SUITE 2 with heaters

NOBLE 2 with heaters

The leg rest heater switch and the backrest heater switch are on the lower left side of the seat when viewed from the basin. Pressing the upper side of the switch turns on the lamp and the power of the heater.

Pressing the lower side of the switch turns off the lamp and the power of the heater.

* It takes about 10 minutes for the surface to warm up after you turn on the power. (The time varies depending on the ambient temperature.)

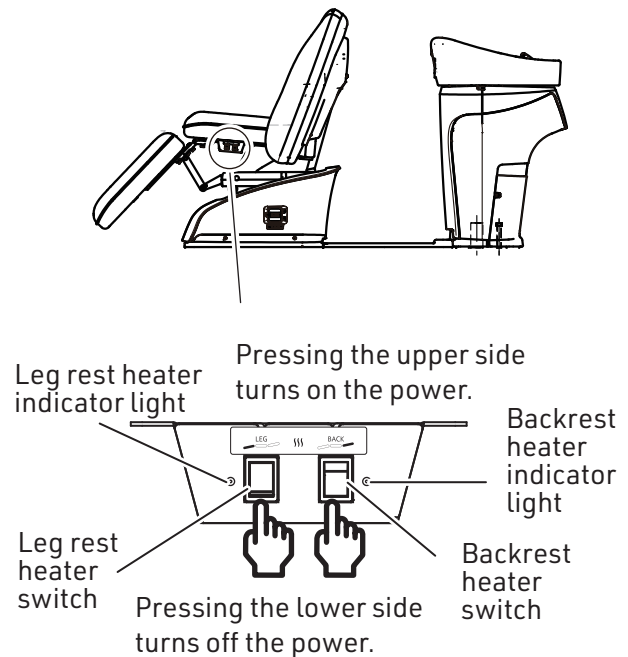

⚠ WARNING

- Make sure to turn off the heater switch(es) when the product will not be in use for a long time, such as at the end of each work day.
- In the event of damage to the upholstery, an unusual odour (burnt smell), or anything abnormal, discontinue use of this product and immediately contact your local authorised Takara Belmont dealer.

⚠ CAUTION

- Always operate the heater switch(es) with your finger.
- The intensity of the warmth felt by the client will vary depending on their physique and clothing. While using the heater(s), check the warmth and the client's condition. If it is too warm, turn off the heater(s).

- The heater(s) is (are) set to a temperature that makes the person feel warm after lying for a while (around 40°C).

The surface of the leg rest or backrest may not feel warm to the touch.

- The heater(s) is (are) designed to maintain a constant temperature, but that temperature varies from product to product.

Cleaning Instructions

Maintenance should be performed after using the product to keep it clean at all times. Stains left uncleaned may result in the growth of mold.

WARNING

- Before cleaning, turn off the power switch and disconnect the power plug from the outlet. Otherwise, an electric shock or fire may result. Also, there is a risk of injury due to unexpected movement of this product.
- Do not wash this product with water. Mechanical failure or electric shock may result.

CAUTION

Some metal parts and mechanical sections of the product have sharp edges. Take care not to injure your hands or fingers during cleaning.

Maintenance of Individual Parts

Leather parts

Gently wipe them with a dry, soft cloth.

For severe staining

Plastic parts

Wipe with a soft cloth wet with neutral detergent diluted about tenfold with water, followed by wiping with a cloth wet with water, then carefully wipe with a dry cloth.

Moving parts

Wipe these parts with a soft, dry cloth.

Metal parts

Do not wipe them with a damp cloth. Moisture, let alone water, is bad for these parts. If the parts become wet, wipe them dry immediately. Failure to do so may result in rust developing or failure of electrical parts.

- The following materials must not be used:
Volatile chemicals, such as thinner, alcohol, remover, gasoline, and kerosene; acid, alkaline or chlorine-based detergents; antiseptic solutions strongly corrosive to metals (Povidone Iodine, etc.); waxes containing abrading agent; and sponges containing abrading agent*.
* These may be used on the ceramic basin only.
- Do not use a brush, scrubbing brush, etc. for cleaning. It will leave scratches or render the stains unremovable. However, the following cases are exceptions:
 - Using a toothbrush on the shower head plate and the foaming water outlet of the shower head [See pages 43.]
 - Using a melamine sponge or a soft toothbrush on the ceramic part inside the basin [See page 39.]
- Do not dry the leather parts with hot air from a hair dryer or similar device.
- Do not clean the leather parts using organic solvents, detergents containing abrasives, bleach, etc. The surface may deteriorate, and the texture and gloss may change.

When restarting use of this product after a long period of time, make sure to perform cleaning. After cleaning, make sure to confirm that the product operates appropriately.

Cleaning Instructions

Basin

Wipe away dirt with a soft sponge that has been wetted with water, wrung out tightly, and applied with cream cleanser (such as Jif). After wiping, rinse off the cleanser thoroughly with water and wipe the basin thoroughly with a dry cloth. Use a soft toothbrush to clean the areas that are difficult to reach with a sponge.

If there are any stains that cannot be wiped away, scrub them with a melamine sponge dampened with water.



CAUTION

- Do not use metal scrubbing pads, hard brushes, or cleansers containing alumina minerals (such as PIKAL) on the basin. Scratches may result.
- Do not use cream cleanser or melamine sponges on plastic parts such as the tap and the thermostatic control knob, or on surface-processed metal parts such as neck-related parts. Scratches may result.

With cotton swabs, carefully clean the shower head holder, the thermostatic control knob, the tap, and the areas around the neck cushion and head cushion attachment fittings.

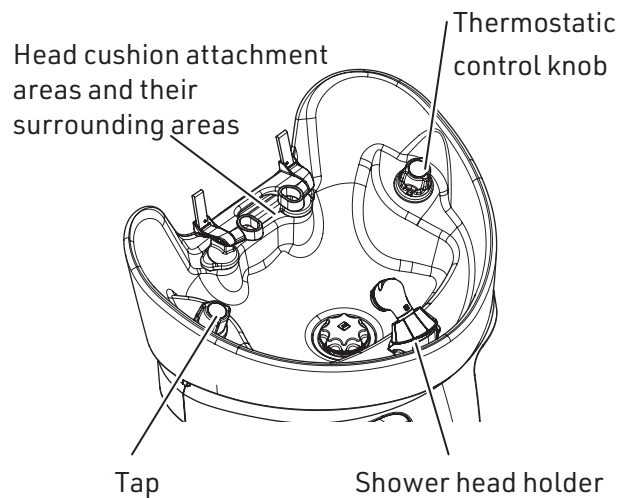

Cleaning Instructions

Drain cap

Wash the area around the gasket attached to the outer periphery of the drain cap with water to remove any dirt such as hair or chemicals. The drain cap is a consumable. If the water drains out quickly when you fill the basin, the drain cap may deteriorate, so replace it (for a charge).

To replace the drain cap, contact your local authorised Takara Belmont dealer.

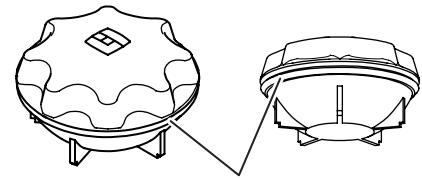

Drain cap gasket

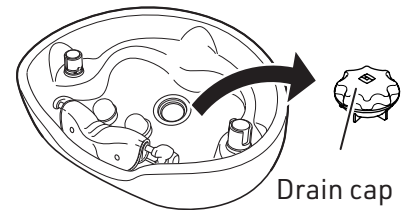

⚠ CAUTION

When not in use, the drain cap must be removed from the drain and kept outside the basin. If the drain cap is not removed, it may close the drain accidentally, and if water is accidentally turned on and you do not notice it, the basin may overflow and cause a water leak.

- Carefully handle the drain cap. If dropped, it may become damaged.
- The drain cap gasket is fixed to the drain cap. Do not apply force to the gasket to remove it. The gasket may be damaged, causing water to drain quickly when you fill the basin.

Hair catcher

Remove the hair catcher under the drain cap and remove any accumulated hair. The hair catcher is a consumable. When it becomes noticeably dirty or deteriorates on the surface, replace it (for a charge).

⚠ CAUTION

Clean the hair catcher as often as possible. If possible, clean the hair catcher after each client's shampooing. If you continue to use the hair catcher without cleaning it, the drain will become clogged with accumulated hair, causing water to overflow and becoming unsanitary.

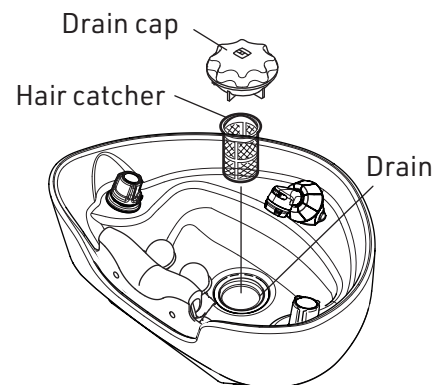

Neck cushion and head cushions

After finishing work for the day, wash these parts with water, thoroughly wipe off the moisture with a dry towel, and hang them to dry in the shade.

If they are very dirty, wash them with neutral detergent diluted about tenfold with water, rinse them with water, wipe them with a dry, soft cloth, and hang them to dry in the shade.

The neck cushion and head cushions are soft and easily scratched on the surfaces. They may tear if scraped with the fingernails. Rub them with the balls of your fingers to wash them.

The neck cushion and head cushions are consumables. When they become noticeably dirty or deteriorate on the surface, replace them (for a charge).

To replace the neck cushion and head cushions, contact your local authorised Takara Belmont dealer.

⚠ CAUTION

- If a chemical solution gets on the neck cushion or head cushions, wash it off immediately. Deterioration or discolouration may result.
- Clean the neck cushion and head cushions every day. Stains left uncleaned may cause the growth of mold.

Cleaning Instructions

Sponge

The sponge is a consumable. If the sponge makes noises rubbing against the shower hose, the sponge may deteriorate, so replace it (for a charge). To replace the sponge, contact your local authorised Takara Belmont dealer.

See 'Removing the shower head holder cover' [page 42], and remove the cover as instructed.

- Remove the sponge from the shower hose, and wash it with water.
- After washing the sponge, hold it in both hands to squeeze out the water.
- Clean the sponge every day.
- After cleaning the sponge, attach it to the shower hose, and place it back inside the cover.

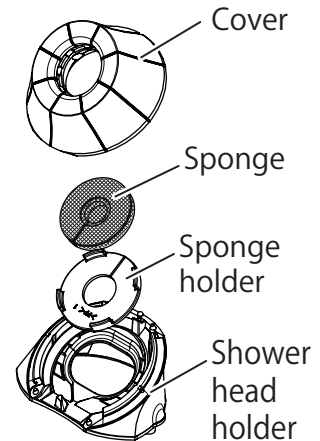

CAUTION

- When cleaning the sponge, do not take it out of the net but leave it in there. If part of the sponge has come out of the net, fit it back inside the net.
- Do not twist the sponge. Damage to the parts may result.
- The sponge must be attached hard side up. Be careful not to attach it upside down.

Attaching the sponge to the shower hose

Open the slit in the sponge to attach the sponge to the shower hose between the cover and the sponge holder.

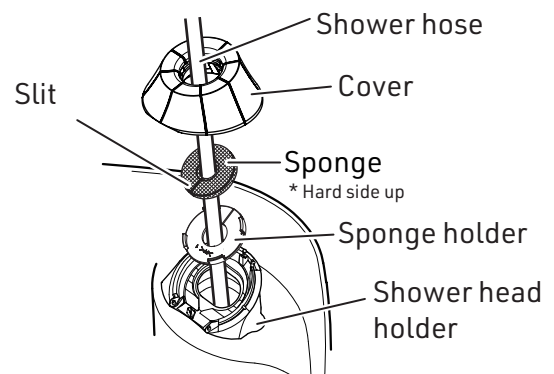

CAUTION

The sponge must be attached hard side up. Be careful not to attach it upside down.

How to replace the shower head holder cover

If the shower head holder cover becomes easily detached, replace it (for a charge).

To replace the shower head holder cover, contact your local authorised Takara Belmont dealer.

<How to replace>

1 Remove the shower head (as shown in the illustration on the right).

2 Remove the shower head holder cover from the shower head holder.

See 'Removing the shower head holder cover' [page 42], and remove the cover as instructed.

3 Remove the shower head holder cover from the shower hose.

Press the socket against the shower head holder cover to remove the cover.

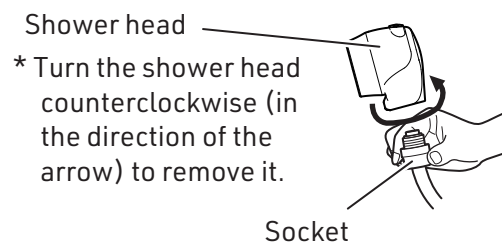

<When removing>

<When attaching>

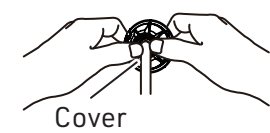
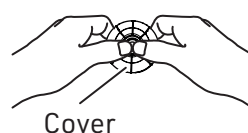

Cleaning Instructions

4 Attach a new shower head holder cover.

Installation tips

Place a plastic bag over the socket at the end of the shower hose, and press it against the shower head holder cover; it will go in smoothly.

5 Attach the shower head holder cover to the shower head holder.

See 'Attaching the shower head holder cover' [page 42], and attach the cover as instructed.

Removing the shower head holder cover

1 Turn the cover counterclockwise.

Turn it (about 5°) until it clicks.

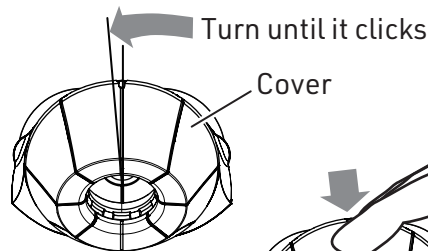

2 Pinch the cover as shown in the illustration to deform it in the vertical direction, releasing the catch on the inside.

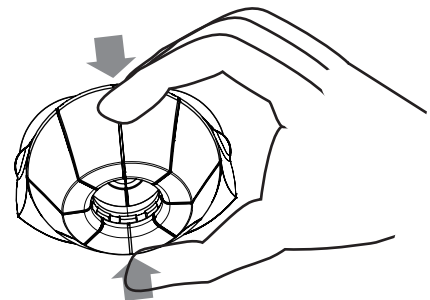

CAUTION

Do not apply excessive force to remove the shower head holder cover. This may exert stress on the assembled parts and damage them.

Attaching the shower head holder cover

Align the notch in the cover with the protrusion on the shower head holder, and press the cover until it snaps into place.

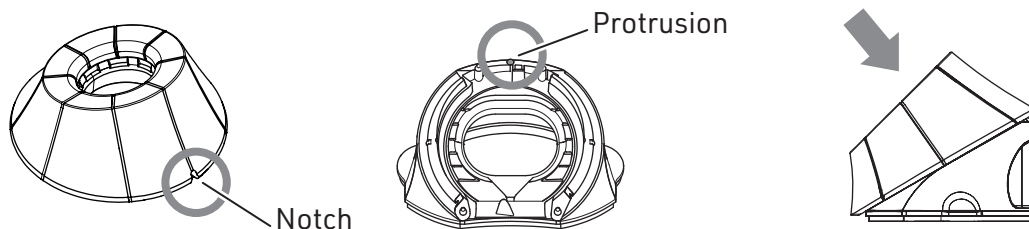

* If the shower head holder cover becomes easily detached, replace it (for a charge).
For replacement, see [page 41].

Cleaning Instructions

Shower head

- 1 Turn the shower head plate counterclockwise to remove it. From the shower head plate, take out the foaming water outlet and the rubber gasket.

Do not remove the O-ring.

- 2 Clean the shower head plate (wash with water).

- Clean the shower head plate once a week.
- Use a toothbrush or similar tool to remove any limescale or other dirt that has accumulated around the shower holes in the shower head plate.

- 3 Clean the foaming water outlet (wash with water).

- Clean the foaming water outlet about once a month (as a guideline).
- Use a toothbrush or similar tool to remove any limescale or other dirt that has accumulated on the foaming water outlet.

- 4 Put the parts back together.

- (1) Into the shower head plate, place the foaming water outlet and the rubber gasket in that order.
- (2) With the spray side of the shower head plate facing downwards, attach the shower head plate to the shower head body. Turn the shower head plate clockwise until the protrusion on it is aligned with that on the shower head body.

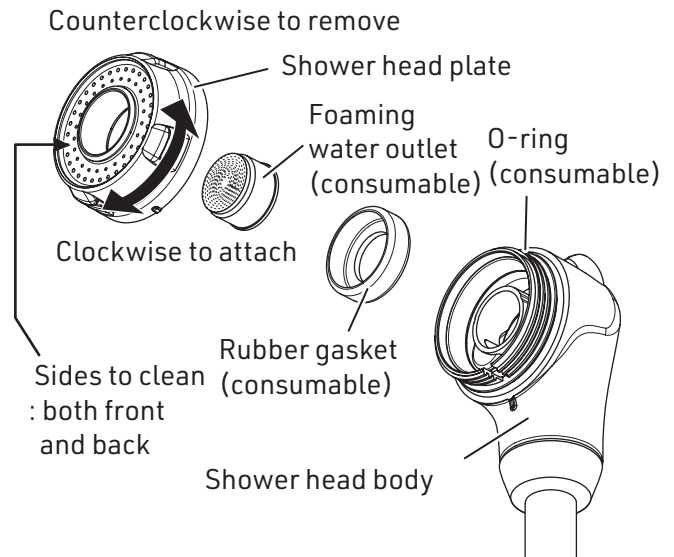

Run water through the foaming water outlet in the direction shown in the illustration.

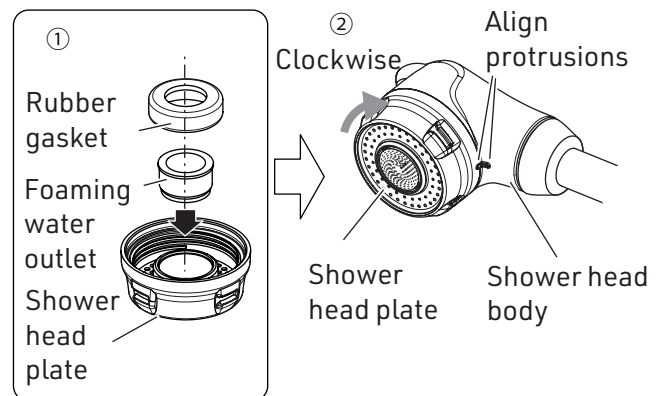
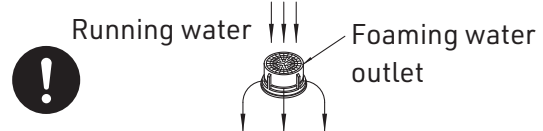

CAUTION

- Be sure to attach the rubber gasket. If the rubber gaskets are not attached, there is a risk of spouting from both the foam and shower spouts even if the water spout is switched.
- Turn the shower head plate securely until it is aligned with the protrusion. If not, there is a risk that water will come out from both the low-splash mode and shower mode even if you switch the shower head mode.

Cleaning Instructions

Tablet case (optional)

Cleaning the tablet case (optional item) (washing with water)

- Clean the tablet case once a week.
- Use a toothbrush or similar tool to remove any limescale or other dirt that has accumulated around the shower holes.

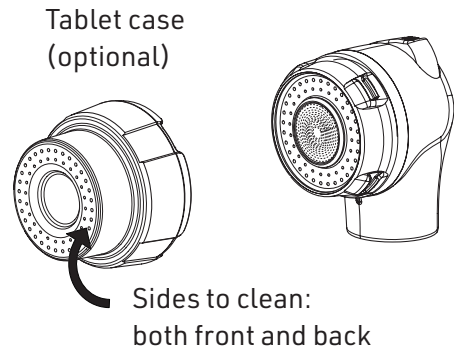

Strainers

To ensure the basin's long life, clean the strainers (built into the check valves) regularly. You can request Takara Belmont to perform cleaning and drain water for a charge. For details, please contact your local authorised Takara Belmont dealer.

⚠ CAUTION

- In cold regions, make sure to implement measures to prevent freezing, such as draining water. Otherwise, water leakage may result.
- When draining and cleaning the strainers, exercise utmost care to avoid the exposure of nearby electrical parts to water. Otherwise, the equipment may not work properly or electricity may leak and cause fire.

1 Prepare the required tool and (two or more) cloths.

Required tool: Flathead screwdriver

Cloths: (Two or more) cloths to absorb water

2 Remove the maintenance cover.

- (1) While lightly pressing the left and right tabs, lift the maintenance cover about 20 mm.
- (2) While further pressing the tabs, lift the bottom of the maintenance cover to remove the cover.

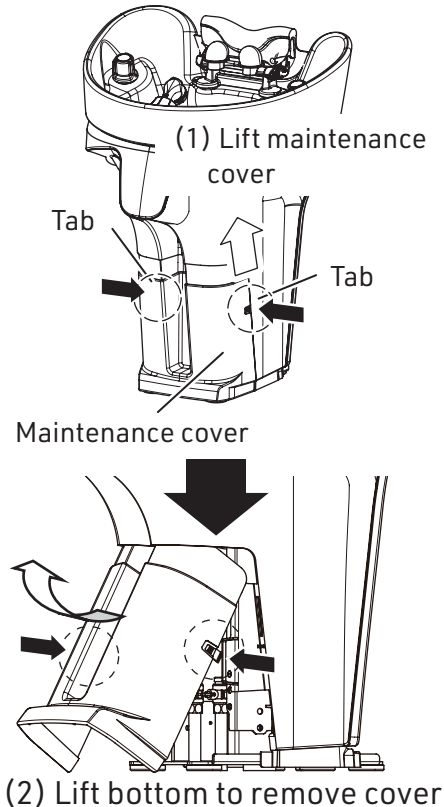

After removing the maintenance cover, check that there are no water leaks inside the basin body. If water leaks, the plumbing inside the basin may be damaged, so contact your local authorised Takara Belmont dealer.

3 Lay some of the cloths on the floor near the hot and cold water pipes.

⚠ CAUTION

- If there are electrical parts such as wiring nearby, exercise utmost care to avoid exposure to water. Otherwise, electricity may leak and cause fire.
- The hot water pipe is hot. Be careful not to touch it with your bare hands.

Cleaning Instructions

4 Close the hot and cold water stop valves.

To prevent water leakage, always make sure the stop valves are completely closed before draining and cleaning the strainers.

5 For each check valve with a strainer, while holding a cloth under the valve, remove the strainer to drain the water.

Required tool: Flathead screwdriver

CAUTION

Be careful when removing the strainer and draining water from the hot water pipe. Hot water may come out.

6 After cleaning the strainers, put them back on the check valves and tighten the strainers securely.

* Both the cold and hot water pipes need draining and cleaning.

7 Wipe up any spilled water and remove the cloth(s) laid on the floor.

CAUTION

- Tighten the strainers securely. Loose tightening may result in water leakage.
- Immediately wipe off any drain water spilled onto the floor.

8 After checking that the strainers are tightened firmly, open the stop valves.

Check that the check valves with strainers are not leaking.

If a strainer is leaking, check to see if it is loose, and if so, tighten the strainer.

If the strainer is not loose, close the stop valve again and take out the strainer. Check that there is no hair or other debris on the threads of the strainer, and if there is any, remove it.

If these steps do not stop the leak, stop using the product and contact your local authorised Takara Belmont dealer

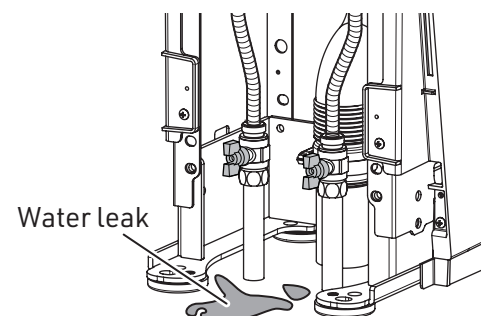
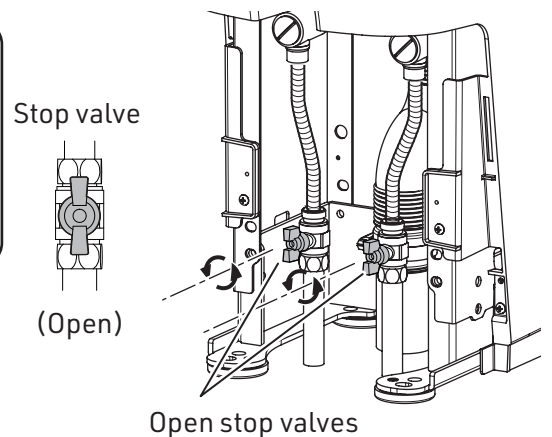
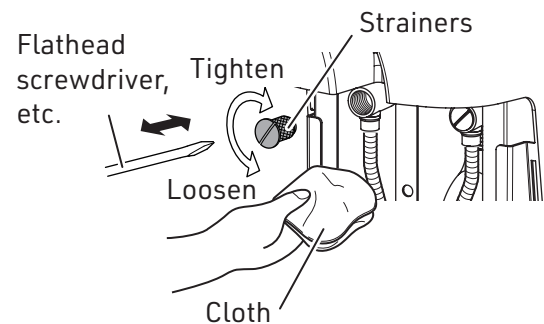
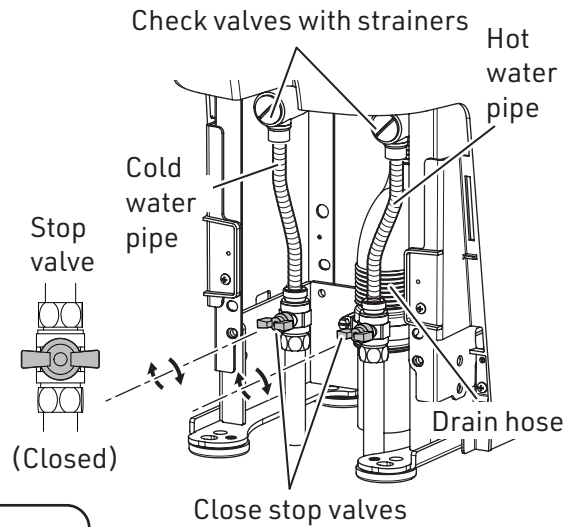

Cleaning Instructions

Strainers

9 Reattach the maintenance cover to the basin body.

<Water leakage inspection>

Once a week (as a guideline), open the maintenance cover and check that there is no water leaking onto the floor. If water leaks, the plumbing inside the basin body may be damaged, so contact your local authorised Takara Belmont dealer.

Inner tray (optional)

Wash it with water, thoroughly wipe off the moisture with a dry towel, and hang it to dry in the shade.

If it is very dirty, wash it with neutral detergent diluted about tenfold with water, rinse it with water, wipe it with a dry cloth to remove moisture thoroughly, and hang it to dry in the shade.

Clean the inner tray every day. Stains left uncleaned may cause the growth of mold.

Wash it with water, thoroughly wipe off the moisture with a dry towel, and hang it to dry in the shade.

If it is very dirty, wash it with neutral detergent diluted about tenfold with water, rinse it with water, wipe it with a dry cloth to remove moisture thoroughly, and hang it to dry in the shade.

Clean the inner tray every day. Stains left uncleaned may cause the growth of mold.

Inner tray
(optional)

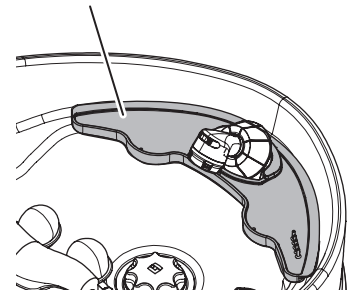

Troubleshooting

If any of the following problems occur, take the troubleshooting steps before calling for repair. If taking the corrective actions does not bring the equipment back to normal operation, immediately stop using the product, turn off the power switch, disconnect the power plug, and contact your local authorised Takara Belmont dealer.

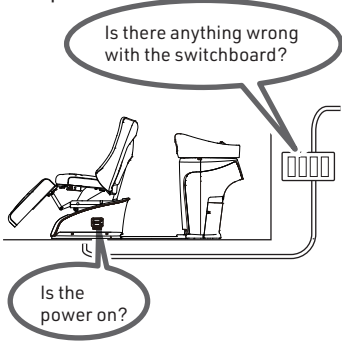
Problem	Check item	Troubleshooting tip
<p>The seat, backrest, or leg rest do not operate.</p>  <p>Is there anything wrong with the switchboard?</p> <p>Is the power on?</p>	Is the power switch on?	Turn on the power switch. [page 22]
	Is there a blown fuse or breaker in the switchboard in your salon?	Replace the fuse on the switchboard or turn on the breaker.
	Is the product operated continuously for a long duration?	<p>This is due to the overheating protection device.</p> <p>⇒ Wait for about 10 minutes before operating the chair again.</p> <div style="border: 1px solid black; padding: 2px; display: inline-block;">Overheating protection device</div> <p>This is a protection device to prevent abnormal overheating of the inside of the equipment due to continuous operation, etc. When the overheating protection device is activated, the chair will temporarily stop operating.</p>
The hot/cold water does not turn on.	Is the stop valve for the hot/cold water open? [page 45]	Open the stop valve. [page 45]
There is a noise when the hot/cold water is turned on.	Does the noise change when you turn the tap to adjust the flow rate?	Adjust the flow rate before use. [page 27]
	Does the noise stop when you remove the foaming water outlet [page 43] and turn on the water?	Clean the foaming water outlet to remove any clogs in it. [page 43]
The water is not hot enough.	Is the water heater set to an appropriate temperature?	Adjust the water heater to an appropriate temperature.
	Is an appropriate temperature set using the thermostatic control knob?	Adjust the thermostatic control knob to an appropriate temperature. [page 28]
The drain does not drain well.	Is the hair catcher clogged with hair?	Remove any hair clogs from the hair catcher. [page 40]

Troubleshooting

Problem	Check item	Troubleshooting tip
Is hot water or water discharged properly from the shower head?	Is the shower head plate loose?	Fully turn the shower head plate until it is aligned with the projection. [Page 43]
	Discharge hot water or water, and visually confirm that hot water or water is properly discharged from the shower head. Check for water leakage from the joint between the shower head plate and the shower head or between the shower head and the shower hose. Also check for turbidity of hot water and water.	Internal gaskets may have been worn if water leaks from the joint between the shower head plate and the shower head or between the shower head and the shower hose. Replacement may be required. Contact your local authorised Takara Belmont dealer.
		If hot water or water is not discharged properly or is turbid, the strainer of the check valve may be fouled. Clean the strainer. [Refer to p.44 to 46.]
		If several streams of water from the shower head plate flow outward, the shower head plate may be clogged with limescale and other deposits. Remove and clean the shower head plate. [Refer to p.43.]
The shower head holder cover has come off.		See 'Attaching the shower head holder cover' [page 42], and attach the cover as instructed. If the shower head holder cover becomes easily detached, it is time to replace it. Please contact your local authorised Takara Belmont dealer.
Moving the shower hose makes a squeaking noise.	Does part of the sponge come out from the net? [page 41]	If part of the sponge comes out from the net, fit it back inside the net. If a noise is heard even though the sponge is inside the net, it is time to replace the sponge. Replace it. [page 41]
	Has the shower hose deteriorated and become rough on the surface? (This causes the shower hose to rub against the shower head holder cover, making noise.)	If the problem persists after you wipe the shower hose with a damp towel, it is time to replace the shower hose. Please contact your local authorised Takara Belmont dealer.
The heater does not heat up.(AY-SCES2P*/AY-SCSB2*)	Is the heater turned on?	Turn on the heater. [page 37]
There is a noise at the start of operation.		This phenomenon may be caused by the cooling of the lubricant inside. The noise does not affect functionality, and it will stop after a while. If the noise persists after a while, stop using the product and contact your local authorised Takara Belmont dealer.
The chair does not move fast enough.		This phenomenon may be caused by the cooling of the hydraulic fluid inside. Raise the room temperature or keep the chair moving for a while, and it will return to normal speed. If the operation still does not return to normal, stop using the product and contact your local authorised Takara Belmont dealer.

Daily Inspection

The following inspection should be performed for safe use of the product.



WARNING

Daily inspections must be performed according to the details shown below. Use without performing daily inspections may lead to injury, or damage to the product, accessories, or facilities.

Daily inspection items

Inspection item	Inspection method	Inspection result, action to take in case of failure
Is there any backlash of the basin, backrest, or seat?	Gently press or shake the rear end of the basin, the top of the backrest, and the front end of the seat in the vertical and horizontal directions to check for backlash.	The equipment may malfunction or be damaged or overturned. Stop using the product and contact your local authorised Takara Belmont dealer.
Does the chair operate properly?	Turn on the power switch and check that there is no intermittent warning sound.	Turn off the power switch, wait for about five seconds, and then turn it back on. If the warning sound persists, the position detector may be broken. Stop using the product, turn off the power switch, and contact your local authorised Takara Belmont dealer.
	Press the preset button to check that the seat moves to the preset position properly.	Change the preset position as instructed in 'Changing the Preset Position' [page 24]. If the operation still does not return to normal, stop using the product, turn off the power switch, and contact your local authorised Takara Belmont dealer.
	Press the automatic return button to check that the seat moves to the initial position properly.	The client may not be able to get on or off safely. If the operation does not return to normal, stop using the product, turn off the power switch, and contact your local authorised Takara Belmont dealer.
	Press the UP switch to check that the seat goes up. Press the DN switch to check that the seat goes down.	The client may not be able to get on or off safely. If the operation does not return to normal, stop using the product, turn off the power switch, and contact your local authorised Takara Belmont dealer.
	Check that there is no wobbling or abnormal noise during the operation of the chair.	If there is any wobbling or abnormal noise during the operation of the chair, stop using the product and contact your local authorised Takara Belmont dealer.
	With the backrest in the most upright position, push it towards the basin to check that it is not unsteady.	Malfunction of the chair may result. Stop using the product and contact your local authorised Takara Belmont dealer.
	With the seat raised to the highest position, push it downwards to check that it is not unsteady.	Malfunction of the chair may result. Stop using the product and contact your local authorised Takara Belmont dealer.
	With the seat raised to the highest position, push the leg rest downwards to check that it is not unsteady.	Malfunction of the chair may result. Stop using the product and contact your local authorised Takara Belmont dealer.
	Check that the seat stays in a given position for a certain period and does not sink.	If the seat sinks and does not stay in the position for a certain period, stop using the product and contact your local authorised Takara Belmont dealer.
	Check that the heater is heating up properly. (AY-SCES2P*/AY-SCSB2*)	It may have failed mechanically. Immediately stop using the product, turn off the power switch, and contact your local authorised Takara Belmont dealer.
Is there an unusual odour coming from the chair?	Check that there is no unusual odour or smoke coming from the chair.	Abnormal activation of the chair or fire may result. Immediately stop using the product, turn off the power switch, and report the abnormality to your local authorised Takara Belmont dealer.

Daily Inspection

Inspection item	Inspection method	Inspection result, action to take in case of failure
Is there an unusual odour coming from the chair?	Check that there is no unusual odour or smoke coming from the leg rest. (AY-SCES2P*/AY-SCSB2*)	Abnormal activation of the chair or fire may result. Immediately stop using the product, turn off the power switch, and report the abnormality to your local authorised Takara Belmont dealer.
Is there any damage to the leather that could damage the heater? (AY-SCES2P*/AY-SCSB2*)	Check that the leather is not damaged around the area(s) under which the built-in leg rest (and backrest) heater(s) is (are) located. [See page 18.]	Depending on the model, the leg rest (and the backrest) has a built-in heater. Contact with exposed heater wiring may result in electric shock. In such case, immediately stop using the product, turn off the power switch, disconnect the power plug, and contact your local authorised Takara Belmont dealer.
Is there an unusual odour coming from the shower head holder?	Check that there is no unusual odour coming from the shower head holder.	If the sponge smells even after being cleaned, it is time to replace the sponge. Replace it promptly. [See pages 41-42.]
Does hot or cold water flow properly from the shower head?	Turn on the hot or cold water and visually check the following three points: the water flows from the shower head properly; there is no water leak from the joint between the shower head plate and the shower head body or from the joint between the shower head body and the shower hose; and the hot and cold water is not cloudy.	If water is leaking from the joint between the shower head plate and the shower head body or the joint between the shower head body and the shower hose, the internal gaskets may have become worn. Replacement may be required. Contact your local authorised Takara Belmont dealer.
		If hot or cold water does not flow properly or is cloudy, the strainers in the check valves may be dirty. Clean the strainers. [See page 45.]
		If a few streams of the shower are spraying outside the intended area, the shower head plate may be clogged with limescale or other dirt. Remove the shower head plate and clean it. [See page 43.]
Does the thermostatic control knob work properly?	Turn the thermostatic control knob and check that the temperature is properly controlled and that there are no strange noises. * The sound of running water may be heard. [See page 28.]	If the temperature is not properly controlled or strange noises are heard, there may be a problem with the thermostatic parts inside the basin. Stop using the product and contact your local authorised Takara Belmont dealer immediately.
Is the plating on the tap or the thermostatic control knob peeling?	Visually inspect the appearance of the tap and the thermostatic control knob to check that there are no scratches, cracks, or peeling on their plated surfaces.	The scratches, cracks, or peeling on the plated surface(s) may injure your hand. Replacement is required. Contact your local authorised Takara Belmont dealer.
	Check that the plated surfaces do not feel rough or strange during operation and cleaning.	
Can the basin be filled?	Cover the drain with the drain cap, fill the basin, and check that the water does not drain out.	If the water filled in the basin drains quickly, the gasket in the drain cap may have deteriorated. The drain cap is a consumable. Replace it promptly. [See page 40.]
Are there any parts other than the inside of the basin that are wet?	Check that no parts other than the inside of the basin are wet.	Otherwise, equipment failure or permanent stains may result. Immediately wipe any moisture off any part of the product other than the inside of the basin.
Have the neck cushion or head cushions deteriorated?	Check that the neck cushion and head cushions are not torn, dirty, or saggy on the surface.	The client's neck or head may feel discomfort or become soiled. The neck cushion and head cushions are consumables. Replace them promptly.

Daily Inspection

Inspection item	Inspection method	Inspection result, action to take in case of failure
Is there an unusual odour coming from the drain in the basin?	Check that there is no unusual odour coming from the drain in the basin.	Remove any hair and other debris accumulated in the hair catcher. [See page 40.]
Is there any oil leak?	Check that there is no oil leaking under the base cover of the chair.	Oil may be leaking from the hydraulic cylinder. Stop using the product and contact your local authorised Takara Belmont dealer immediately.
Is the surface on which the basin body is installed wet with water?	Visually check that the area around the installation surface of the basin body is not wet with water.	Water may be leaking inside the basin body. Open the maintenance cover to check the inside [see page 44]. If water is leaking from the plumbing, immediately close the stop valves of the cold and hot water pipes [see pages 44-45], stop using the product, and contact your local authorised Takara Belmont dealer.
Does the tap work properly?	Turn the tap to check that hot and cold water comes out properly and that there are no strange noises. Close the tap to check that the hot and cold water stops completely. * The sound of running water may be heard. [See page 27.]	If you hear strange noises or completely closing the tap does not stop the hot or cold water from running, the stop valve of the tap may be defective. Immediately close the stop valves of the cold and hot water pipes [see page 45], stop using the product, and contact your local authorised Takara Belmont dealer.

Mandatory inspection items at the end of daily work

Inspection item	Inspection method	Inspection result, action to take in case of failure
Is the drain plugged?	Check that the drain is not plugged by the drain cap, a towel, or a shampoo cape.	Remove the objects that are plugging the drain. When the drain is plugged, if the water is accidentally turned on or an increase in water pressure late at night causes a small amount of water to come out, the basin may overflow and cause a water leak.
Is the tap firmly closed?	Fully turn the tap clockwise to check that the water is turned off securely.	Fully turn the tap to turn off the water securely. If the water cannot be completely turned off, there may be a problem with the stop valves of the tap. Close the stop valves of the cold and hot water pipes [see page 45] and promptly contact your local authorised Takara Belmont dealer.

Weekly inspection items

Inspection item	Inspection method	Inspection result, action to take in case of failure
Is there water leakage inside the basin body?	Remove the maintenance cover from the basin to check that neither the plumbing nor the faucet fittings inside are leaking. [See pages 44-45.]	If the plumbing is leaking, either the plumbing or the gaskets may be worn, deteriorated, or damaged. Immediately stop using the product, close the stop valves of the cold and hot water pipes [see pages 44-45], and quickly contact your local authorised Takara Belmont dealer.
Is the drain hose leaking?	Remove the maintenance cover from the basin to check that the drain hose is not leaking. [See pages 44-45.]	If the drain hose is leaking, it may be damaged. Stop using the product and contact your local authorised Takara Belmont dealer immediately.
Is there any limescale or other dirt accumulated on the foaming water outlet or shower head plate?	Remove the foaming water outlet and the shower head plate to check that no limescale or other dirt is adhered to them. [See page 43.]	Use a toothbrush or similar tool to remove the limescale or other dirt, and clean the foaming water outlet and the shower head plate. If the limescale or other dirt is not removed, the foaming water outlet and the shower head plate may become clogged and the shower may not turn on properly.

Regularly Replaced Parts

Takara Belmont designates the following parts as regularly replaced parts:

Drain hose...3 years

- Cracks may be generated in the drain hose due to deterioration and hardening caused by chemicals that are drained, resulting in water leakage.
- Damage to the drain hose may result in water spillage onto and under the floor.

Check valves...3 years

- As the check valves are used for a long period of time, their internal parts may deteriorate, causing problems: the water may no longer come out. In some cases, wastewater that has flowed down the faucet may backflow, contaminating tap water or leading to public health problems.

Hot and cold water supply hoses...3 years

- Cracks may be generated in the hot or cold water supply hose due to deterioration caused by the equipment operation or residual chlorine or copper ions in the tap water, resulting in water leakage.
- Damage to the hot and cold water supply hoses may result in water spillage onto and under the floor.

These are 'regularly replaced parts', which must be replaced periodically to ensure safety and maintain their performance.

Parts that are past the specified replacement period must be replaced (for a charge) even if they can be used without any problem.

Takara Belmont is not liable for any hazards, damage, or defects that may arise from your failure to replace such parts within the specified period. To request replacement, contact your local authorised Takara Belmont dealer.

Standard Period of Use

- The standard period of use for this product is seven years.
- The standard period of use is defined as 'a guideline for the standard period of using the product without any problems in safety under standard conditions of product use with appropriate maintenance and inspection (including replacement of parts) performed'. Please be advised that this is not an indication of the warranty period, and the standard period will differ depending on the environment in which you use the product and the frequency of use. Please contact your local authorised Takara Belmont dealer for maintenance.

Consumables

'Consumables' refer to parts that are expected to undergo wear, deterioration, or changes or damage in appearance with use. Please be advised that the repair and replacement of consumables are not covered under the guarantee and will incur a charge.

(* Degree and timing of wear, deterioration, and damage vary depending on the environment and the conditions under which the product is used.)

In the case of significant wear and deterioration or damage, inspection or replacement of the parts will be necessary. Please contact your local authorised Takara Belmont dealer immediately.

Consumables (The following items are not covered by the warranty and will incur a charge.)

- | | | | |
|---|--|---|---------------------------------------|
| <input type="checkbox"/> Neck cushion | <input type="checkbox"/> Head cushions | <input type="checkbox"/> Drain cap | <input type="checkbox"/> Hair catcher |
| <input type="checkbox"/> Shower head holder cover | <input type="checkbox"/> Sponge | <input type="checkbox"/> Rubber gaskets | <input type="checkbox"/> Shower hose |
| <input type="checkbox"/> Foaming water outlet (foaming inner core, rubber gaskets) in the shower head | | | |
| <input type="checkbox"/> Lubricants (e.g., oil, grease) | | | |

Also, scratches, stains, deterioration, and discoloration on the outer surface of the exterior parts are not covered under the warranty.

Exterior parts

- Covers, frames, and basin
- Upholstery parts (backrest, seat, and leg rest)
- Knobs (e.g., tap, thermostatic control knob)
- Others (e.g., shower head, shower head holder)

Disposal of the Product

When disposing of the product or replaced parts, waste should be processed appropriately according to current laws and regulations in your country.

After-sales Service

1. To request after-sales services, contact your local authorised Takara Belmont dealer.
2. This product is covered by a free-of-charge warranty for one year from the date of delivery. When our technician needs to make a repair service visit to "a remote island or a remote location equivalent to a remote island," the actual fees incurred even during the warranty period may be charged.

Specifications

Model numbers	Basin body	AY-EXES2R* (Colour codes are shown in place of the asterisk '*'.)	[Back wash basin]
	Chair body	AY-SCES2B* AY-SCES2P* AY-SCSB2* (Colour codes are shown in place of the asterisk '*'.)	[ESPOIR 2 Basic, Premium, SUITE 2 and NOBLE 2 without heater] [ESPOIR 2 Premium with heater] [SUITE 2 and NOBLE2 with heaters]
	Seat body	AY-UES2B* AY-UES2PN* AY-UES2PH* AY-USI2N* AY-USI2H* AY-UNB2N* AY-UNB2H* (A colour code is shown in place of the asterisk '*'.)	[ESPOIR 2 Basic, movable leg rest type without heater] [ESPOIR 2 Premium, movable leg rest type without heater] [ESPOIR 2 Premium, movable leg rest type with heater] [SUITE 2 without heater] [SUITE 2 with heaters] [NOBLE 2 without heater] [NOBLE 2 with heaters]
Drive system		Electro-hydraulic	
Outer dimensions		See 'Product Dimensional Drawings' [pages 55-57].	
Initial seat height	ESPOIR 2	Height : 485 mm	
height	SUITE 2, NOBLE 2	Height : 495 mm	
Lifting/lowering stroke		200 mm	
Reclining angle (angle from horizontal)		[Automatic return] 70° to [Preset] 8°	
Leg rest angle (from horizontal)		[Automatic return] 45° to [Preset] 0°	

Specifications

Neck height	800 mm				
Mixed mode	Thermostat type				
Output method and flow rate (when both the hot water supply pressure and the cold water supply pressure are 0.1 MPa)	Shower mode: 10.0 L/min Low-splash mode (water-saving type): 6.6 L/min				
Stop valve	Single valve (handle type)				
Rated voltage	AC 110 V	AC 120 V	AC 220 V	AC 230 V	AC 240 V
Rated frequency	50/60 Hz	50/60 Hz	50/60 Hz	50/60 Hz	50/60 Hz
Rated current AY-SCES2B*	4.3 / 2.8 A	5.7 / 3.4 A	1.7 / 1.6 A	1.9 / 1.6 A	2.1 / 1.7 A
Rated current AY-SCES2P*	4.5 / 3.0 A	5.9 / 3.6 A	1.8 / 1.7 A	2.0 / 1.7 A	2.2 / 1.8 A
Rated current AY-SCSB2*	4.6 / 3.1 A	6.0 / 3.7 A	1.8 / 1.7 A	2.0 / 1.7 A	2.2 / 1.8 A
Operating environment	Temperature	10°C to 30°C			
	Humidity	90% or lower (without condensation)			
Transportation/storage environment temperature	Temperature	-20°C to 70°C			
	Humidity	95% or lower (without condensation)			
Weight	Basin body	AY-EXES2R*	: 36.5 kg		
	Chair body	AY-SCES2*	: 43 kg		
		AY-SCSB2*	: 43 kg		
	Seat body	AY-UES2B*	: 12 kg		
		AY-UES2P*	: 12 kg		
		AY-USI2*	: 12 kg		
AY-UNB2*		: 12.5 kg			
Chair load capacity	1350 N (135 kgf)				

* Regarding the specifications, there may be slight individual differences among the same products.

Product Dimensional Drawings

Overall layout: NOBLE 2

[In mm]

Basin body: AY-EXES2R [Back wash basin]
 Chair body: AY-SCSB2 [SUITE 2 NOBLE 2]
 Seat: AY-UNB2 [NOBLE 2]

Top view

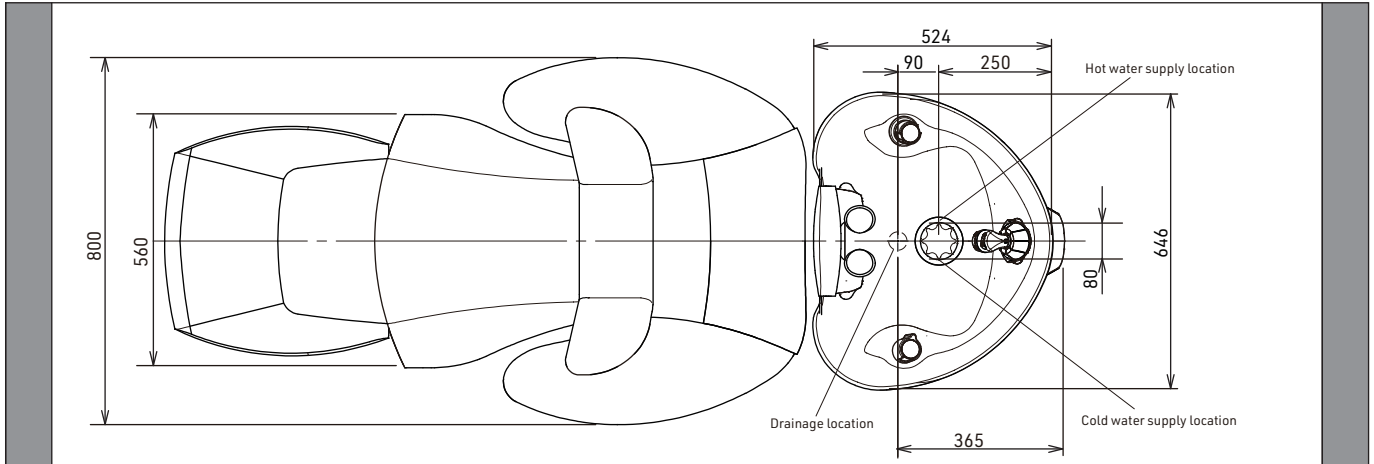

Side view

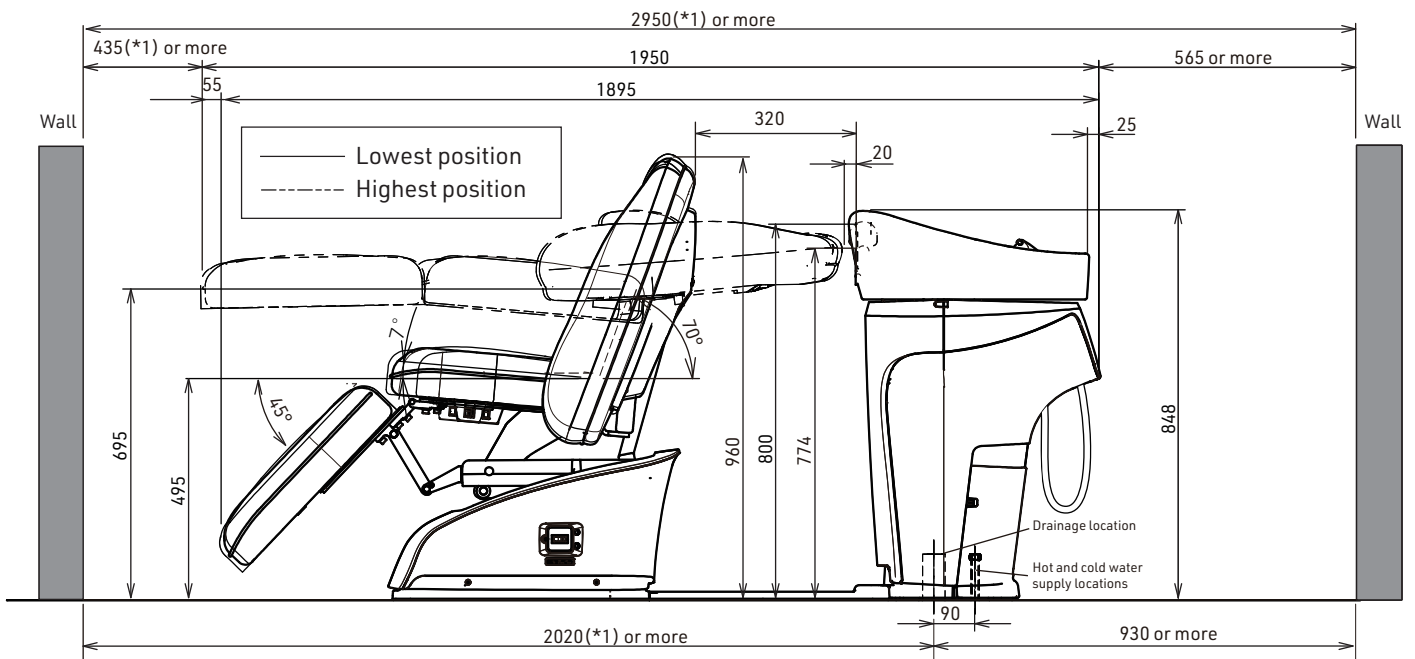

*1: Secure extra space when you are expecting a tall client or if the space is to be used as a passage.

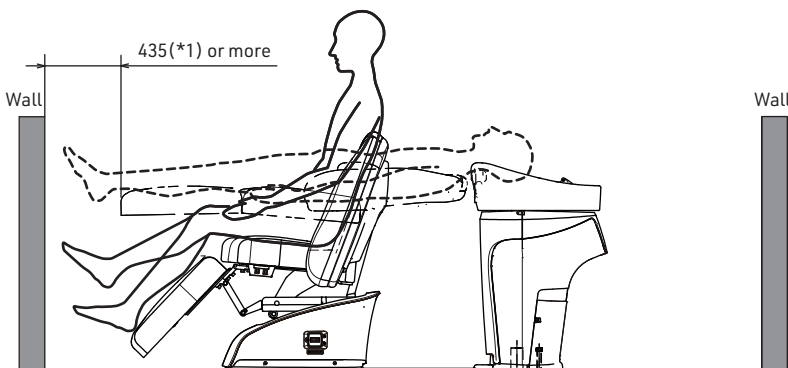

* The dimensions and specifications given here are subject to change for improvement without notice.

MEMO

MEMO



TAKARA BELMONT CORPORATION

1-1, 2-Chome, Higashi-shinsaibashi, Chuo-ku, Osaka, Japan

TEL : +81-6-6213-5945

FAX : +81-6-6212-3680

Printed in Japan